

RANGE OF APPLICATION

Flows up to:	120 m ³ /h
Manometric head up to:	31 m
Maximum working pressure:	10 bar
Temperature range:	-20° to +110°C
Nominal diameter ports:	25 to 80
MEI* of reference:	≥ 0,10

*Minimum Efficiency Index

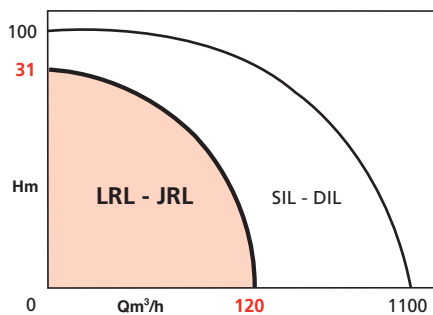

ADVANTAGES

- Low electrical consumption.
- Mounts directly onto horizontal or vertical pipework.
- Not coupled: no need to align the shafts.
- Device to de-aerate the mechanical seal permanently.
- Easy and quick to install.

JRL

- A backup pump permanently available.
- The two pumps can be operated in parallel to increase the flow.
- Manual or automatic pump switchover by MGP box.



• LRL-U: horizontal motor

• JRL: horizontal motors



• LRL: vertical motor

• JRL: vertical motors



• LRL: moteur vertical

LRL - JRL

SINGLE AND DOUBLE IN-LINE PUMPS

Heating - Air conditioning - E.C.S.*
50 Hz

*A.C.S. Standard: contact us

APPLICATIONS

- Heating small and medium multiple dwellings.
 - Air conditioning.
 - Domestic hot water systems.
 - Many industrial and agricultural applications.
 - Heating greenhouses..
 - Transferring antifreeze.
 - Circulating iced water.
- A.C.S. Standard: contact us.

LRL - JRL

DESIGN

Hydraulic part

- Centrifugal, single-stage.
- Intake and outlet ports in line.
- Flanged pump housing with ports for connecting pressure gauges, or connector union (version U).
- Bearing lantern linking pump to motor.
- Dynamically balanced impeller, mounted directly on the shaft of the motor.
- Waterproof mechanical seal.

JRL

- Double pump in one housing.
- The two pumps are hydraulically separated by silent-operating valve.

Motor

- IE2
- One end of shaft lengthened.
- The rotor shaft's guide bearings selected for silent operation.

Speed:	1450 - 2900 rpm
3 ~ winding ≤ 3 kW:	230 V Δ 400 V Y
3 ~ = 4kW:	400 V Δ
Frequency:	50 Hz (option 60 Hz)
Insulation class:	155 (F)
Protection class:	IP 55
EC Compliant:	EN 809

BASIC CONSTRUCTION

Main components	Material
Pump housing	Cast iron EN GJL 250
Bearing lantern	Cast iron EN GJL 250
Shaft	Steel X20 - Cr13
Mechanical seal	Graphite/Carbide Si/EP
Joint of corps	Ethylene Propylene
Impeller	Composite

IDENTIFICATION

LRL 2 03 U - 09/0.25 - P2

JRL 4

single pump	_____
double pump	_____
2 = 2 pole: 2900 rpm	_____
4 = 4 pole: 1450 rpm	_____
Nominal diam. of ports (cm)	_____
to connector union	_____
Nominal diam. of the impeller (cm)	_____
Motor power (kW)	_____
Option: ACS version (contact us)	_____

LRL-U – PLAN AND CROSS-SECTION

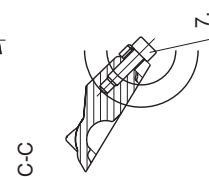
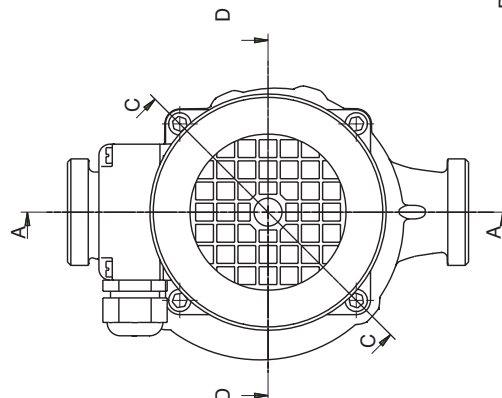
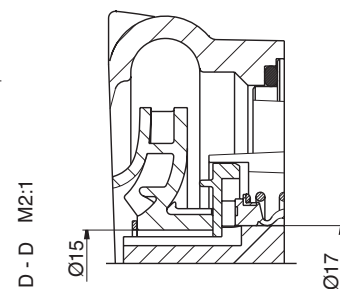
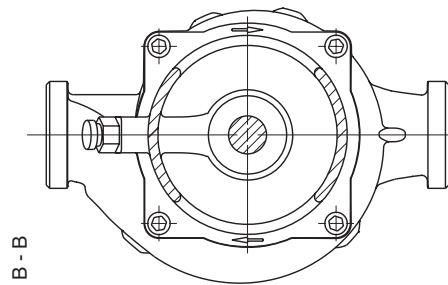
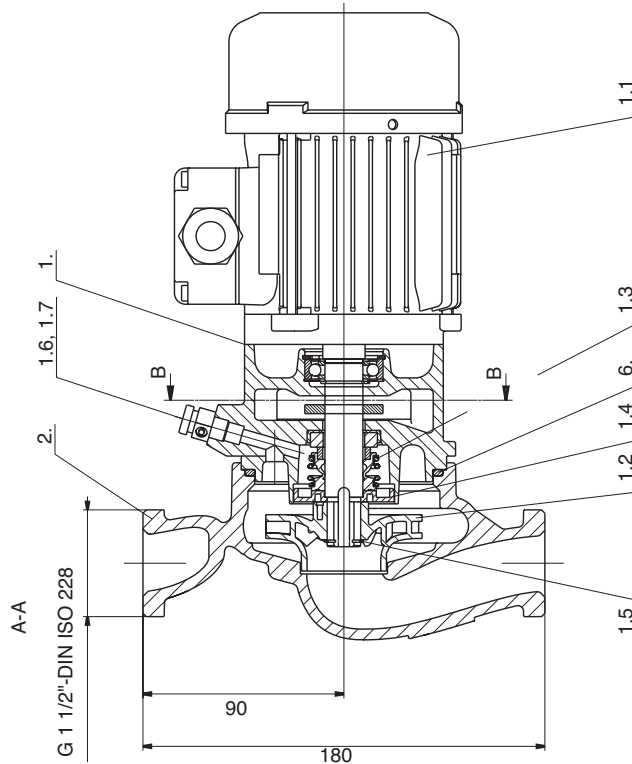

LRL - PLAN AND CROSS-SECTION

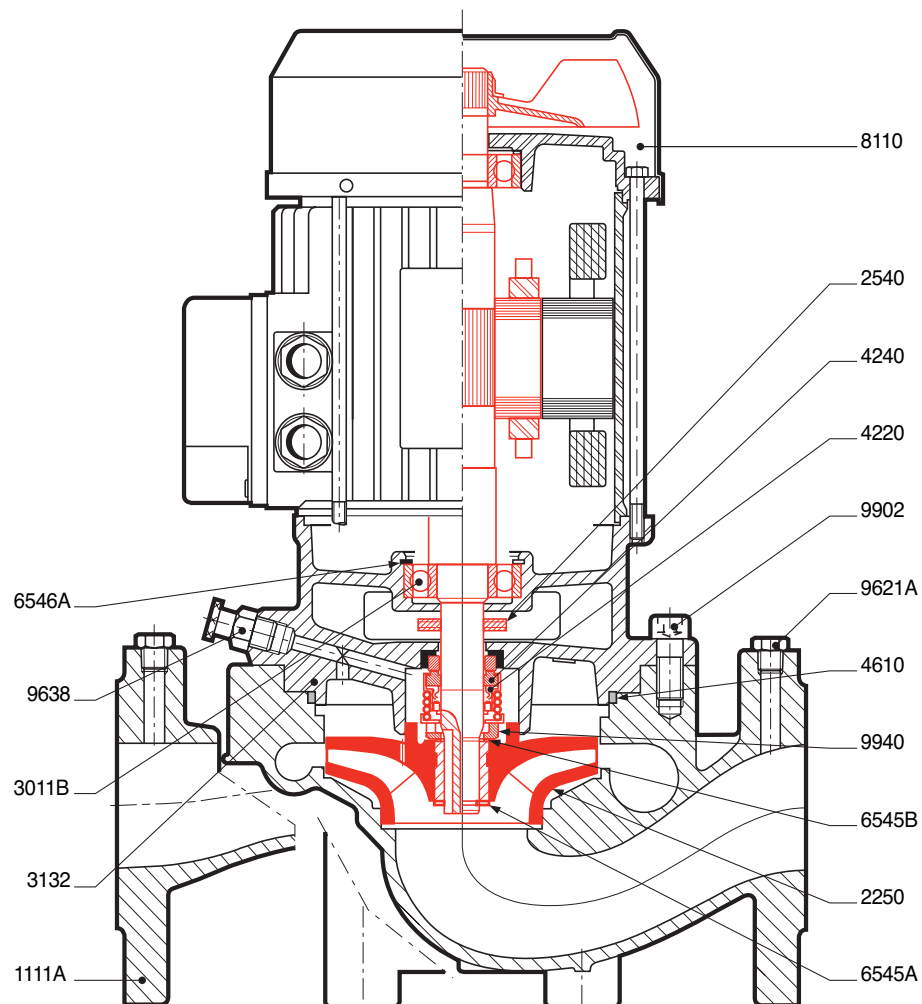

GARNITURE MÉCANIQUE (LRL-JRL)

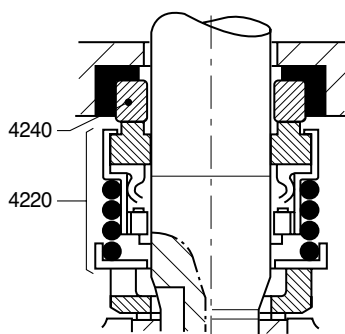

List (common to LRL - JRL)

- 1111A - Single pump housing
- 1111B - Double pump housing
- 2250 - Impeller
- 2540 - Deflector
- 3011B - Guide bearing
- 3132H - Bearing lantern
- 4220H - Rotating ring of mechanical seal
- 4240H - Fixed ring of mechanical seal
- 4610H - Fixed ring of mechanical seal
- 6545A - Snap ring on shaft
- 6545B - Snap ring on shaft
- 6546A - Circlip of bearing
- 8110H - Electric motor
- 9621A - Plug for pressure gauge take-off
- 9621B - Drain plugs (JRL)
- 9638 - De-aerator of mechanical seal
- 9647H - Outlet valve (JRL)
- 9902H - Bearing lantern retaining screw
- 9940H - Axial bearing of mechanical seal
- (•) Spare parts recommended

LRL - JRL

JRL – PLAN AND CROSS-SECTION

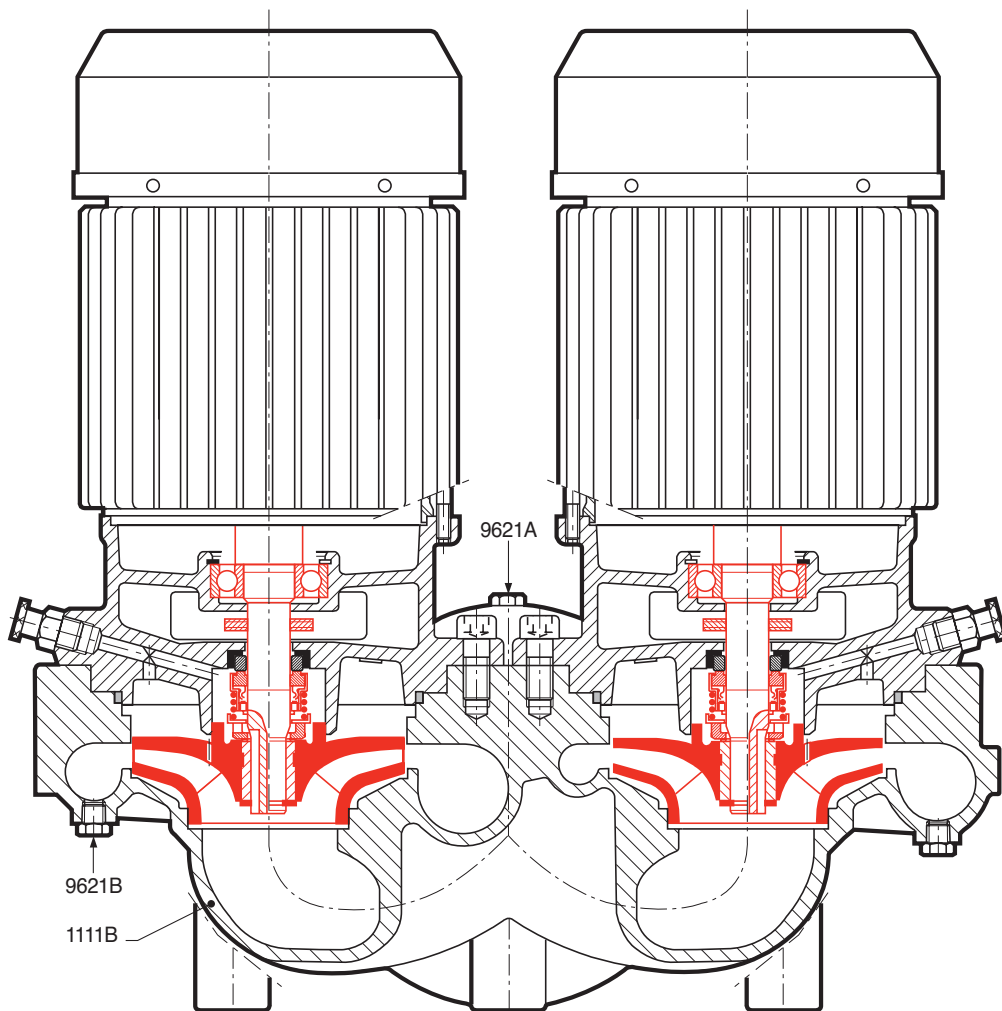

List (common to LRL - JRL)

- 1111A - Single pump housing
 - 1111B - Double pump housing
 - 2250 - Impeller
 - 2540 - Deflector
 - 3011B - Guide bearing
 - 3132H - Bearing lantern
 - 4220H - Rotating ring of mechanical seal
 - 4240H - Fixed ring of mechanical seal
 - 4610H - O-ring pump housing
 - 6545A - Snap ring on shaft
 - 6545B - Snap ring on shaft
 - 6546A - Circlip of bearing
 - 8110H - Electric motor
 - 9621A - Plug for pressure gauge take-off
 - 9621B - Drain plugs (JRL)
 - 9638 - Deaerator of mechanical seal
 - 9647H - Outlet valve (JRL)
 - 9902H - Bearing lantern retaining screw
 - 9940H - Axial bearing of mechanical seal
- (-) Spare parts recommended

MECHANICAL SEAL
(LRL-JRL)

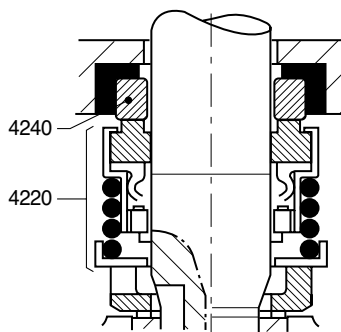

DETAILS OF OUTLET (JRL)
VALVE

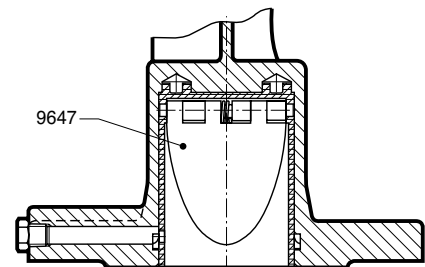

LRL - GENERAL PRESELECTION GRAPHS

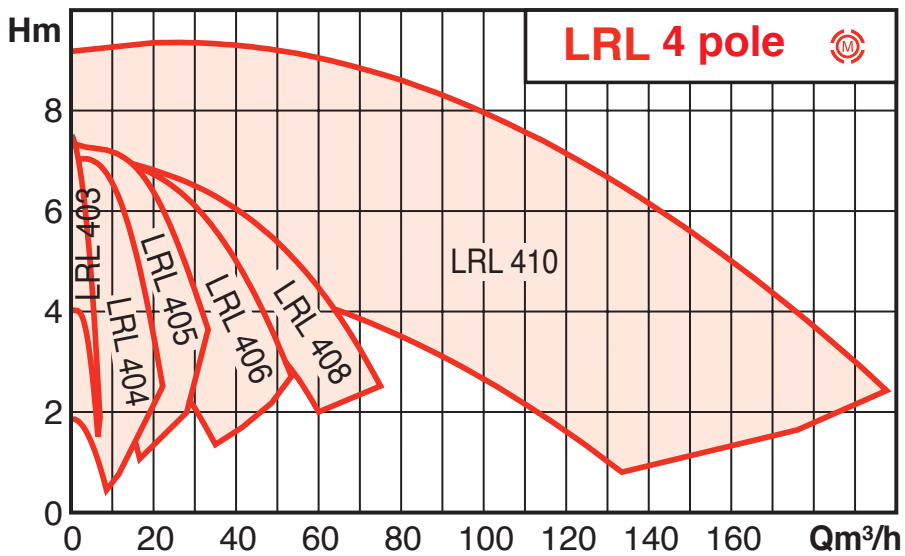
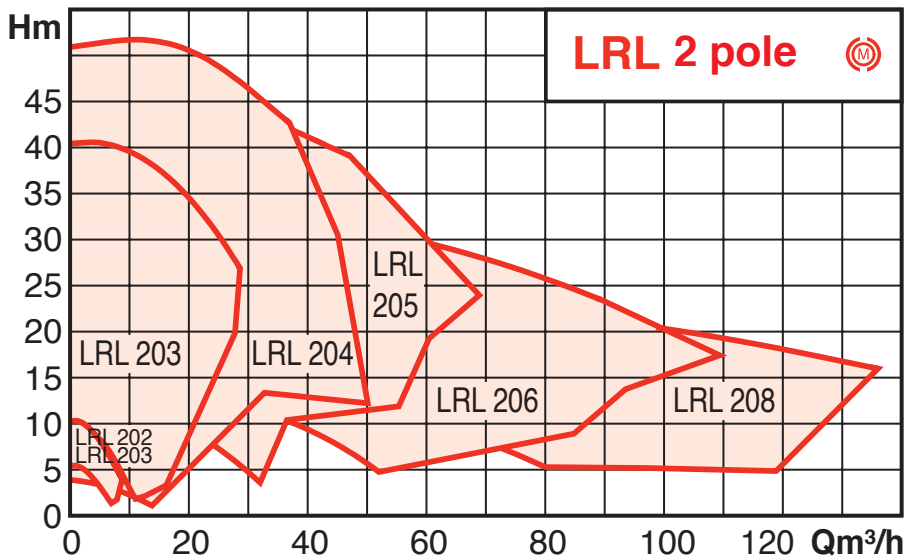

MOUNTING POSITIONS

• mounted directly onto horizontal or vertical pipework

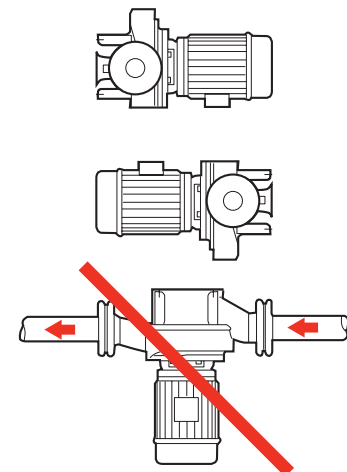
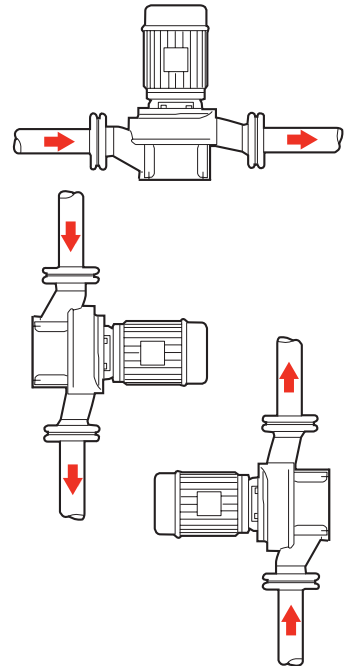

• pumps nominal diameter 65 and 80 mounted on solid base with optional support.

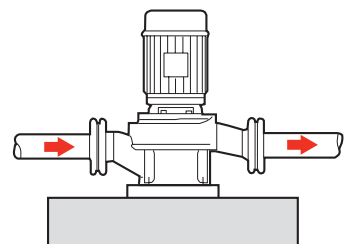

LRL - JRL

JRL - GENERAL PRESELECTION GRAPHS

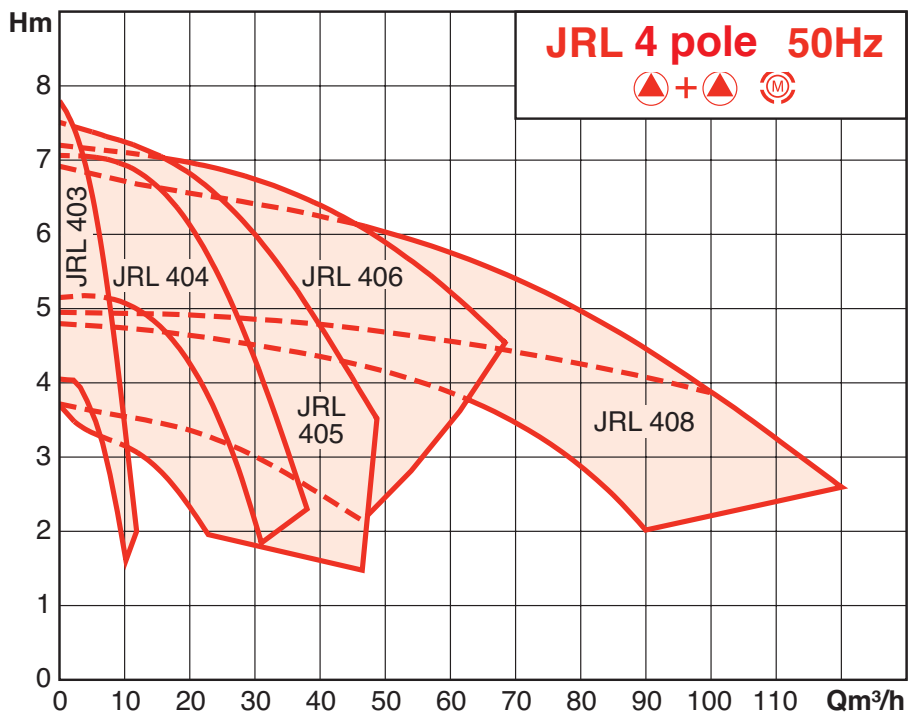
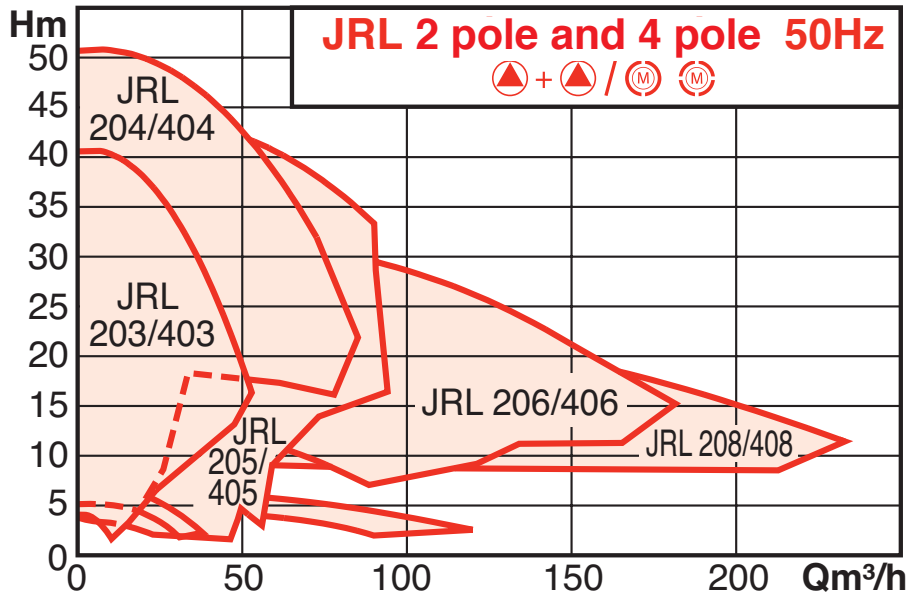

MOUNTING POSITIONS

- mounted directly onto horizontal or vertical pipework

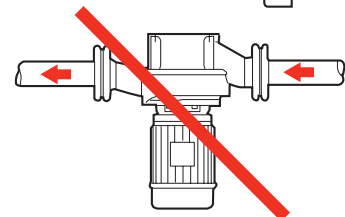
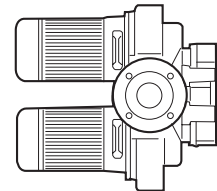
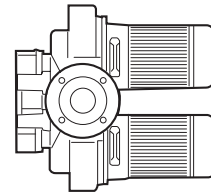
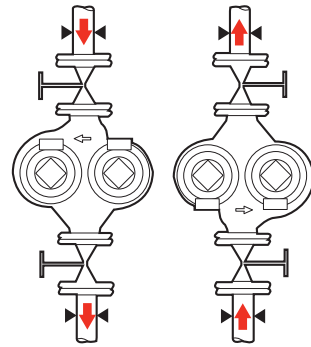
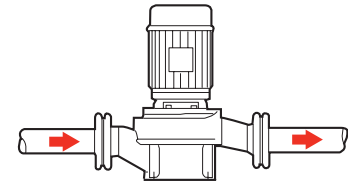

- pumps nominal diameter 65 and 80 mounted on solid base with optional support

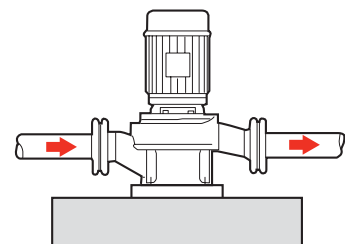

HYDRAULIC PERFORMANCE LRL 4 POLE

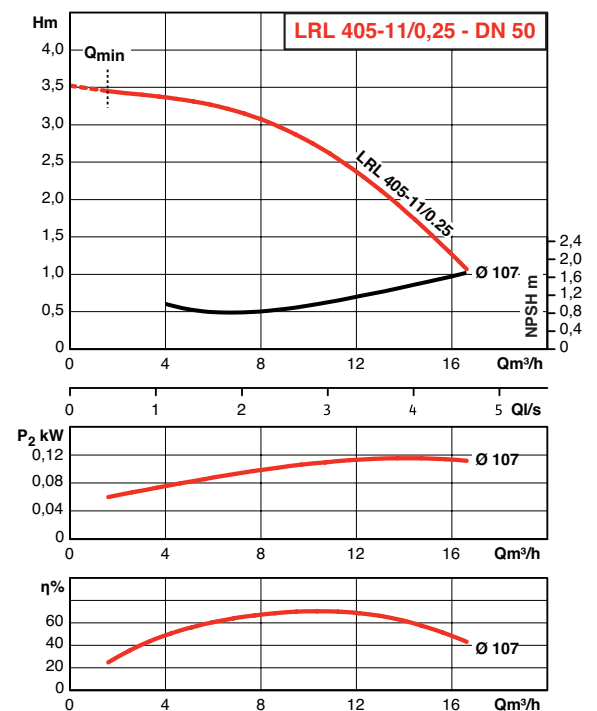
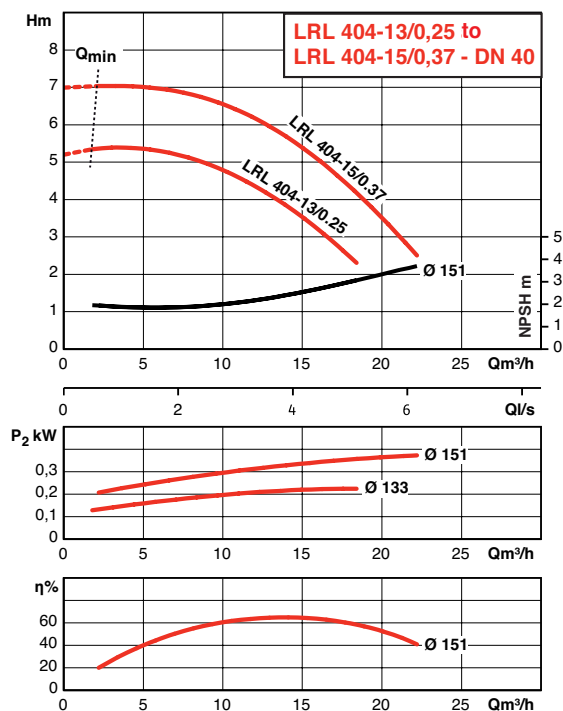
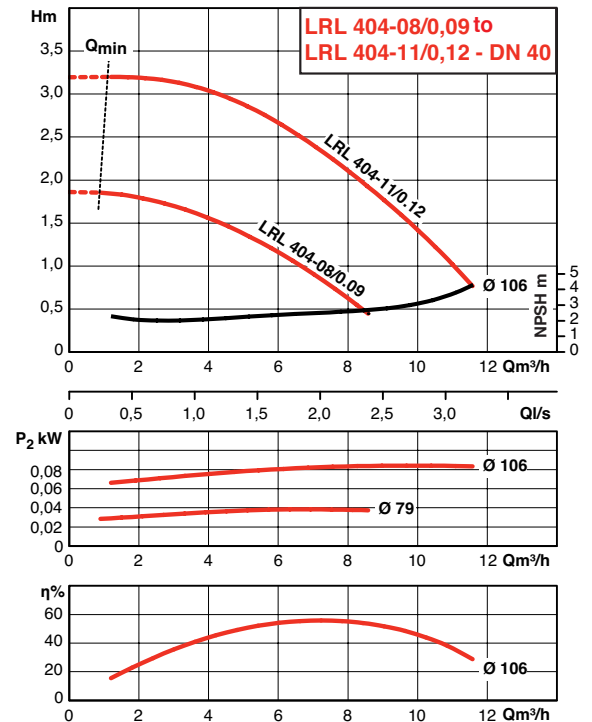
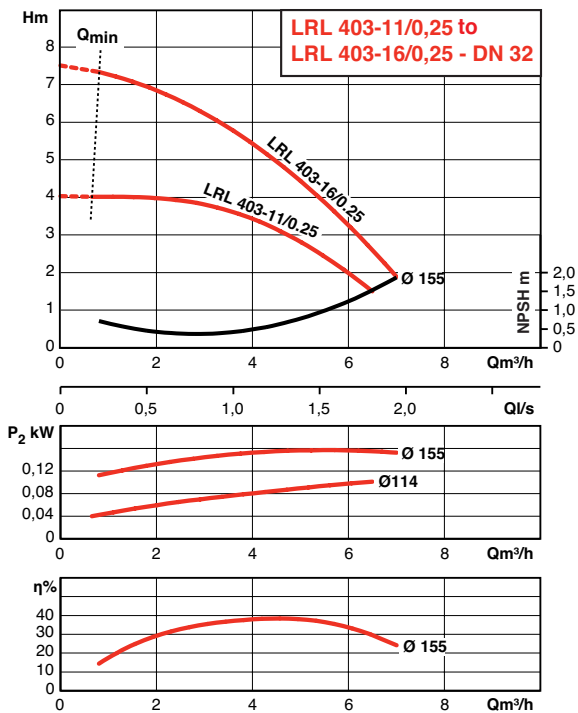

LRL - JRL

HYDRAULIC PERFORMANCE LRL 4 POLE

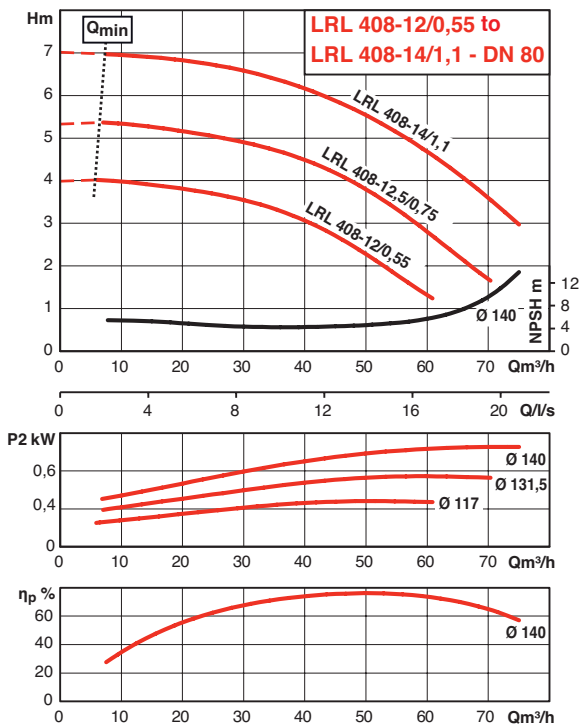
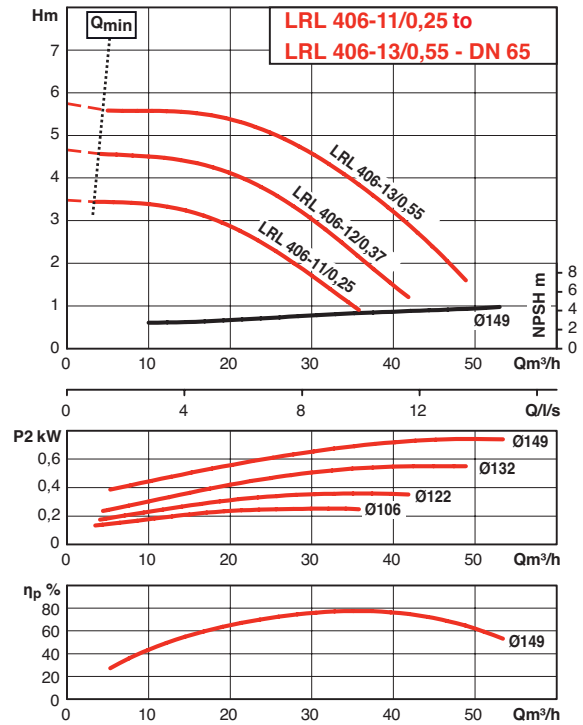
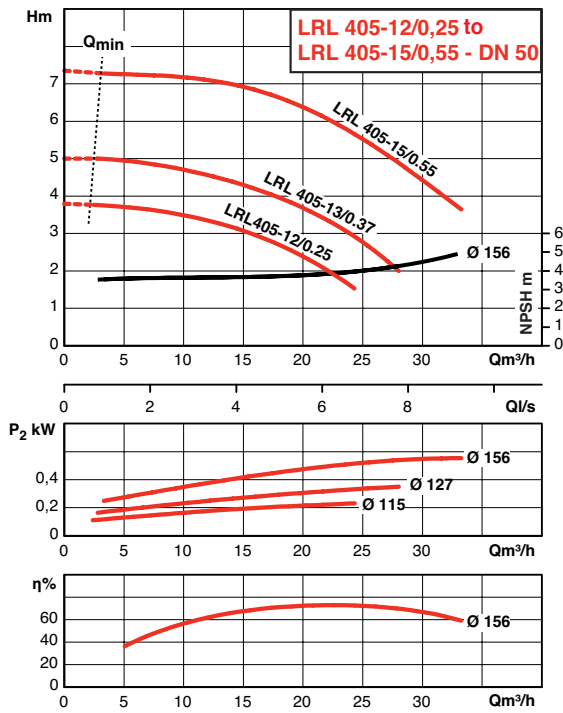

HYDRAULIC PERFORMANCE LRL-U- 2 POLE

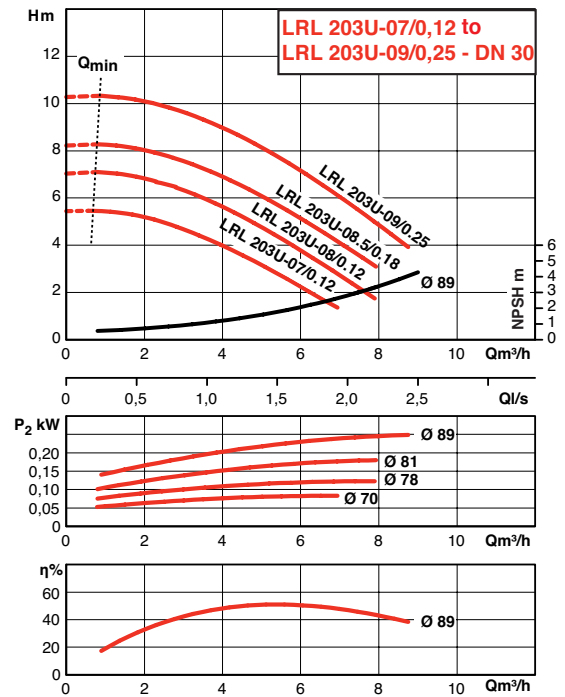
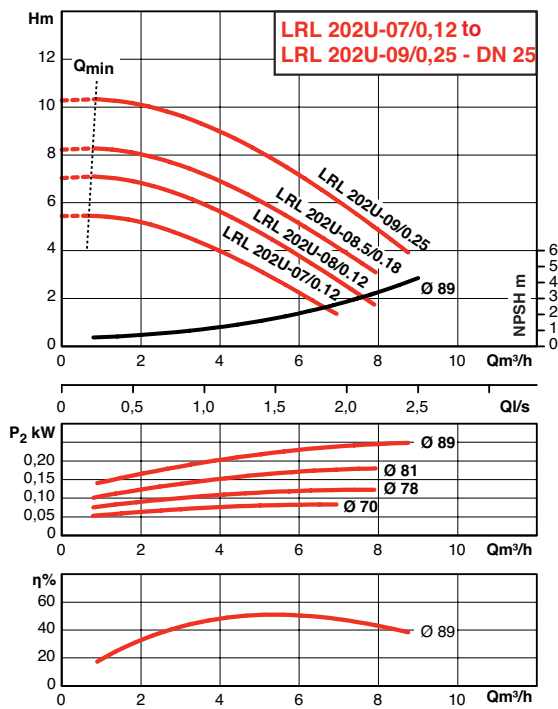

HYDRAULIC PERFORMANCE LRL 2 POLE

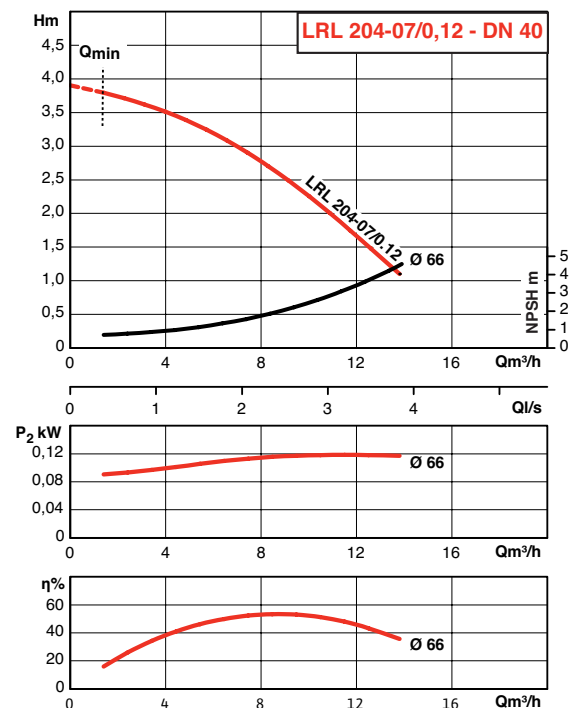
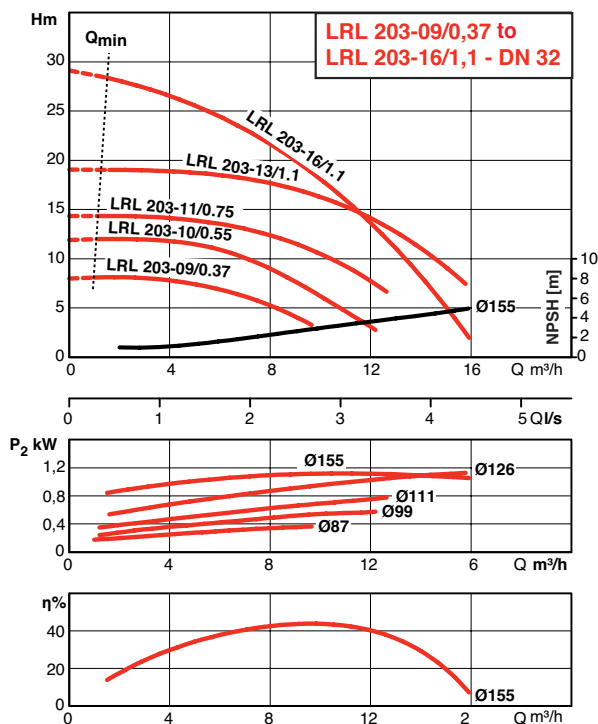

LRL - JRL

HYDRAULIC PERFORMANCE LRL 2 POLE

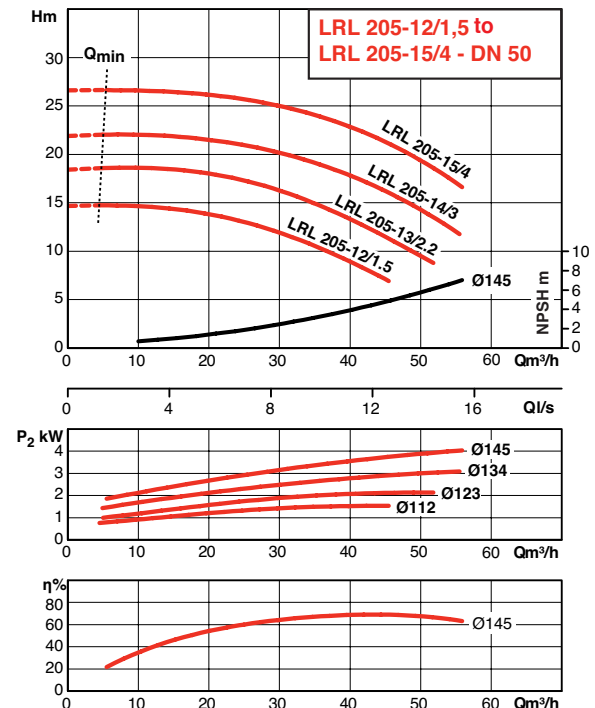
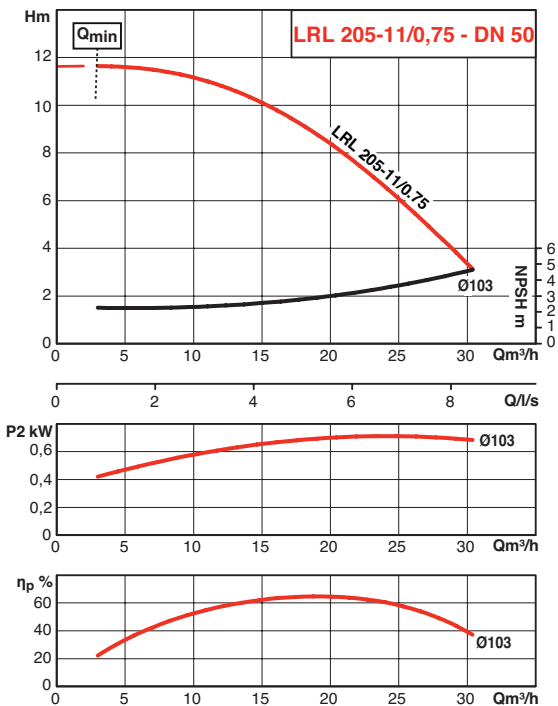
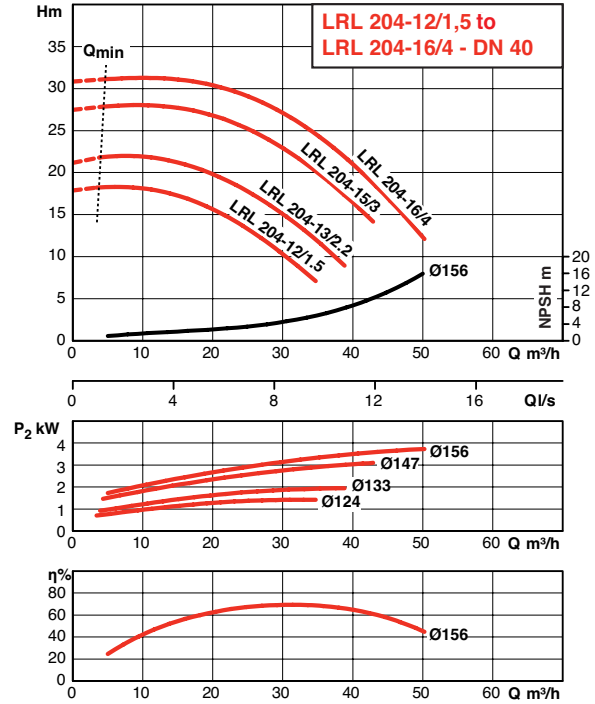
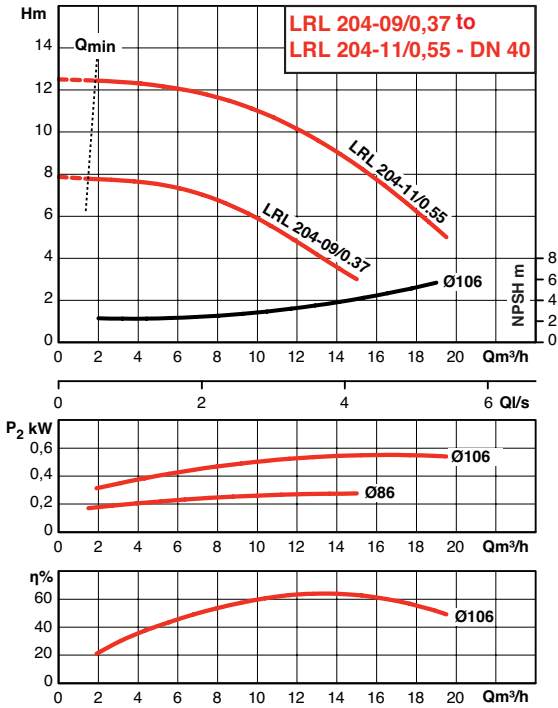

HYDRAULIC PERFORMANCE LRL 2 POLE

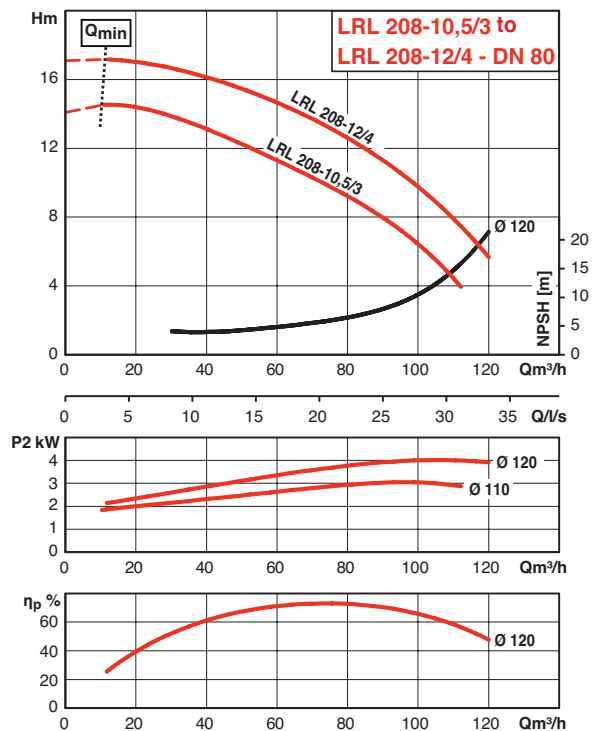
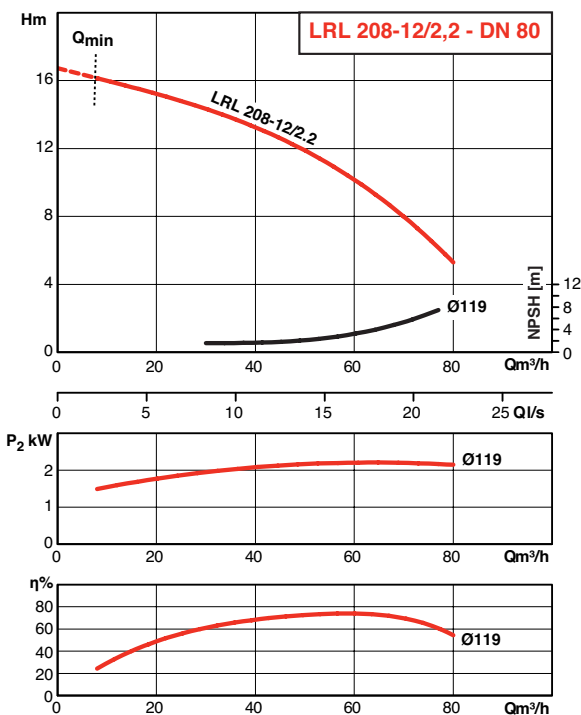
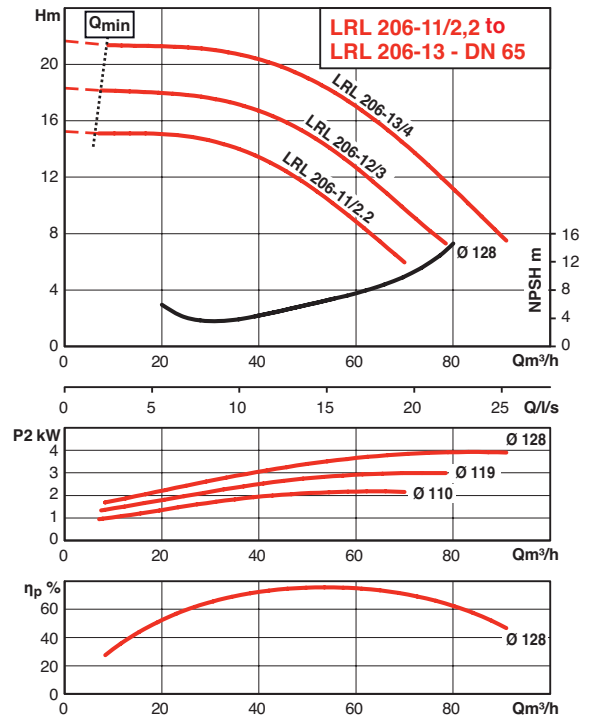
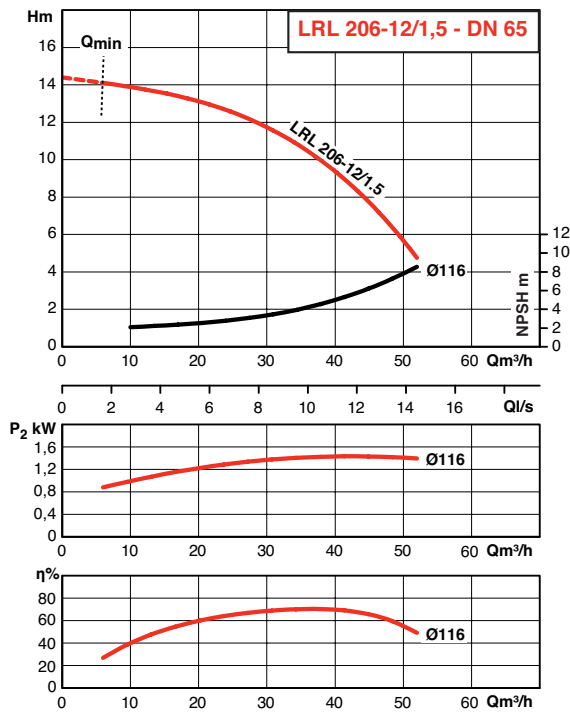

LRL - JRL

HYDRAULIC PERFORMANCE JRL 4 POLE

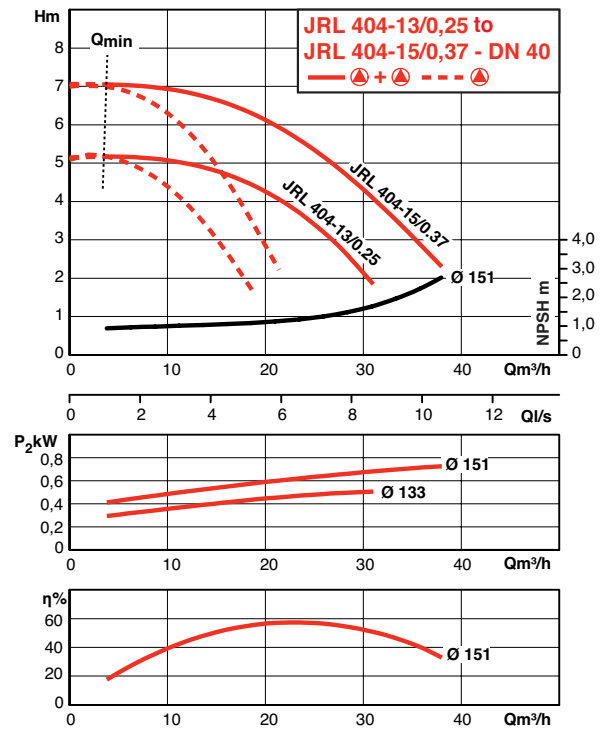
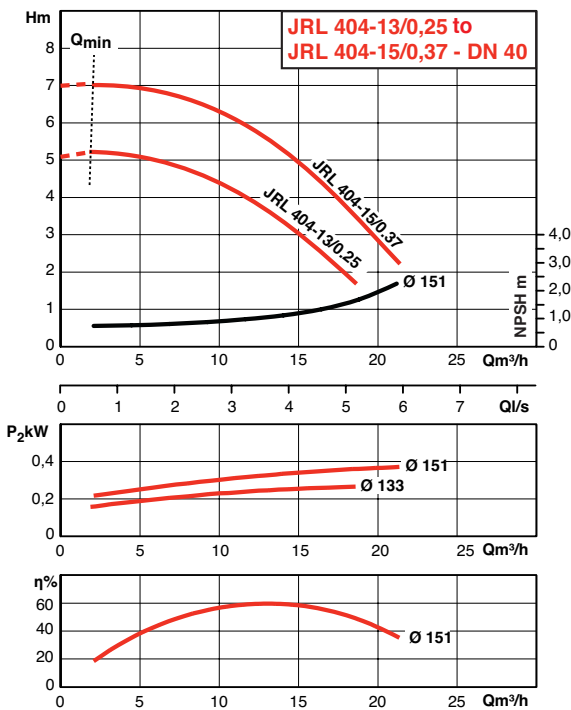
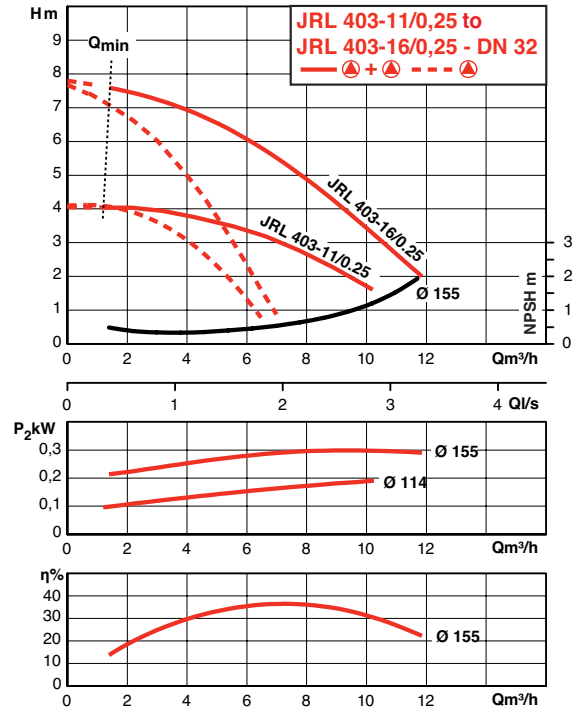
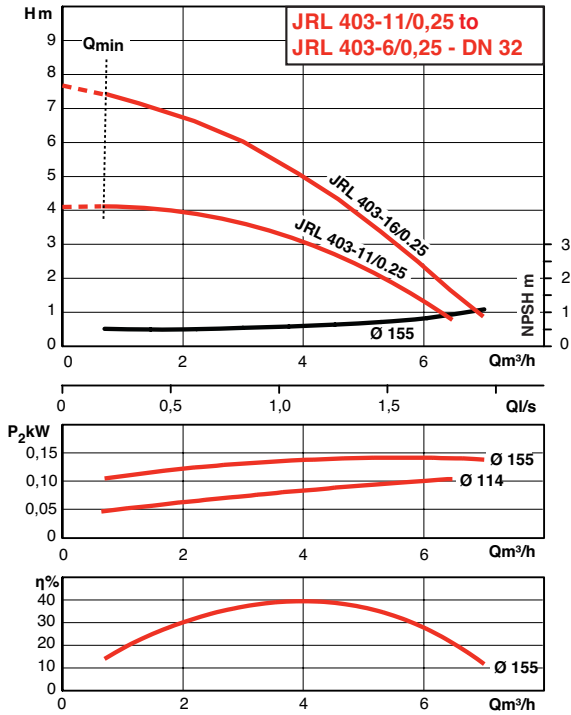

HYDRAULIC PERFORMANCE JRL 4 POLE

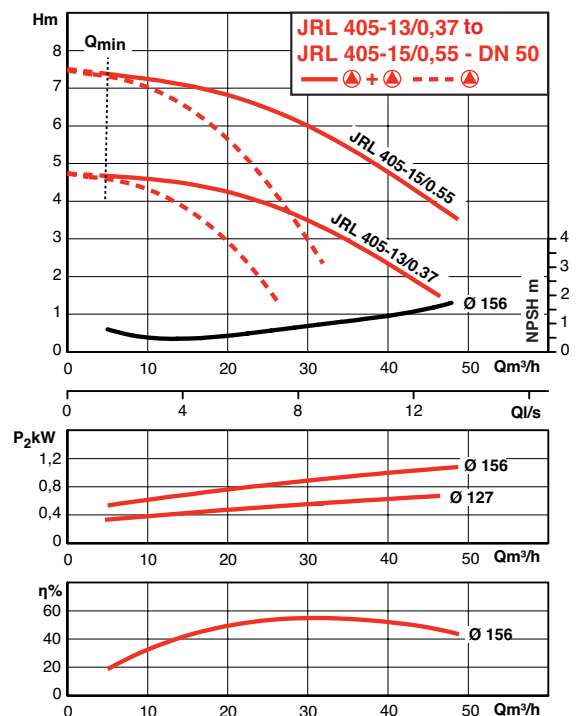
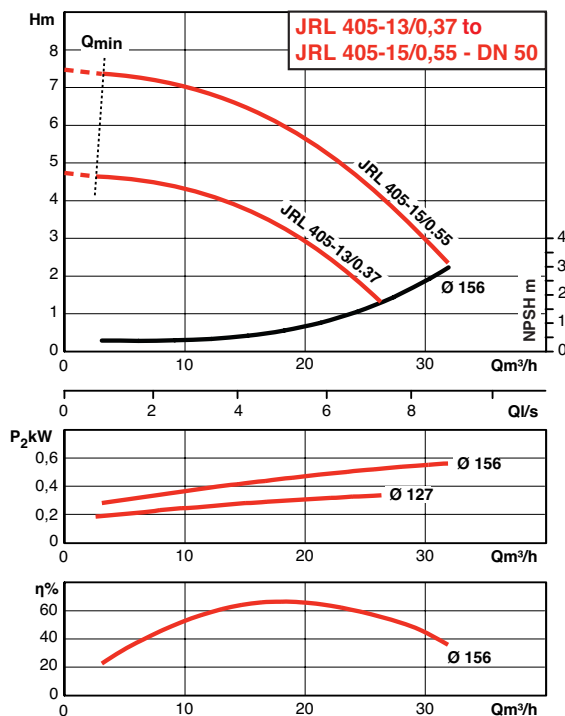
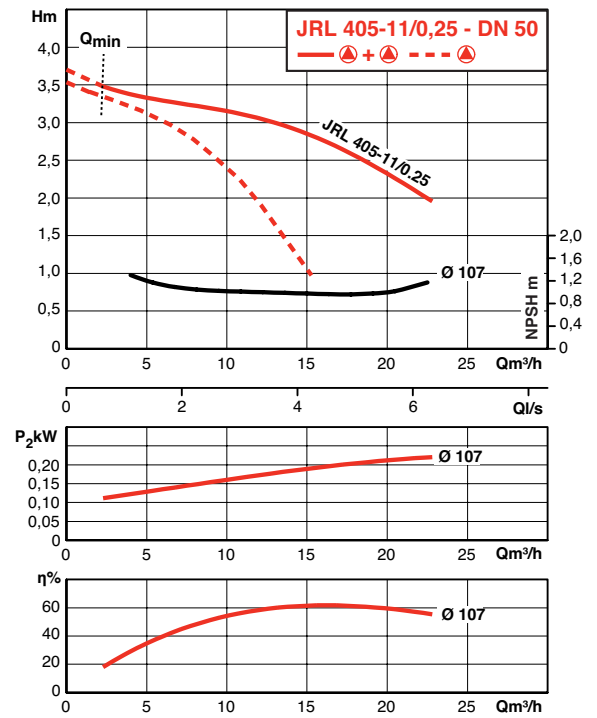
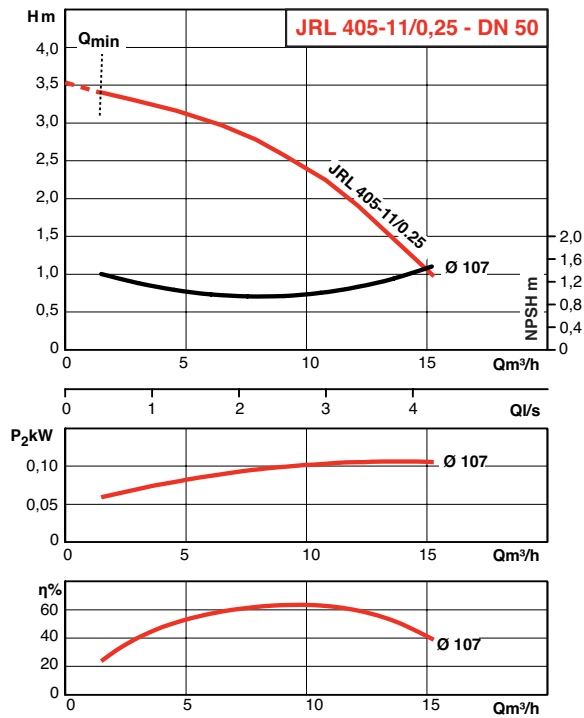

LRL - JRL

HYDRAULIC PERFORMANCE JRL 4 POLE

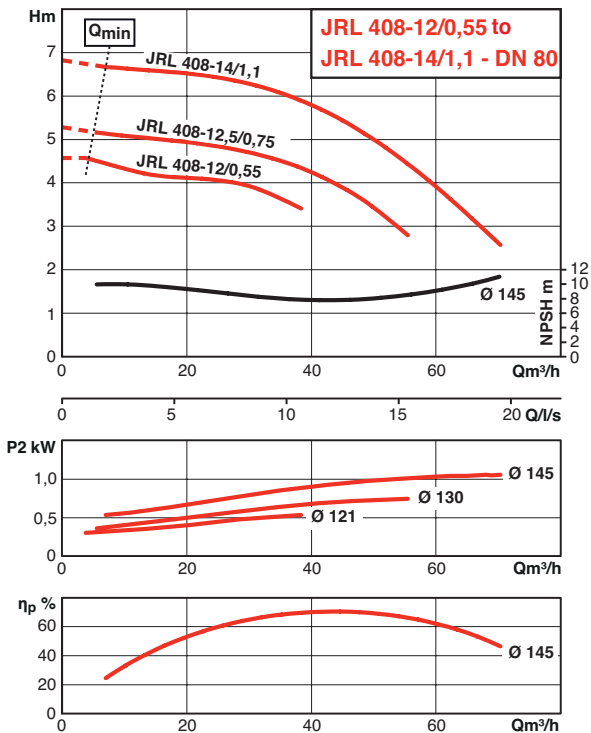
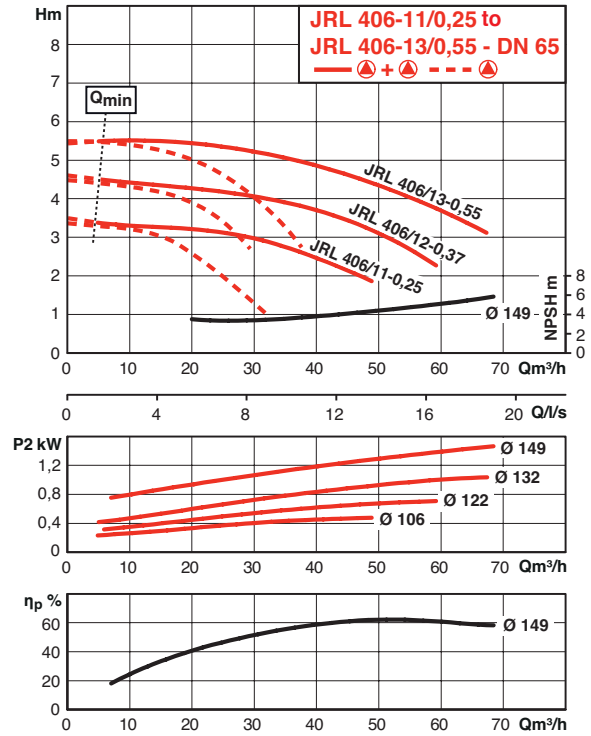
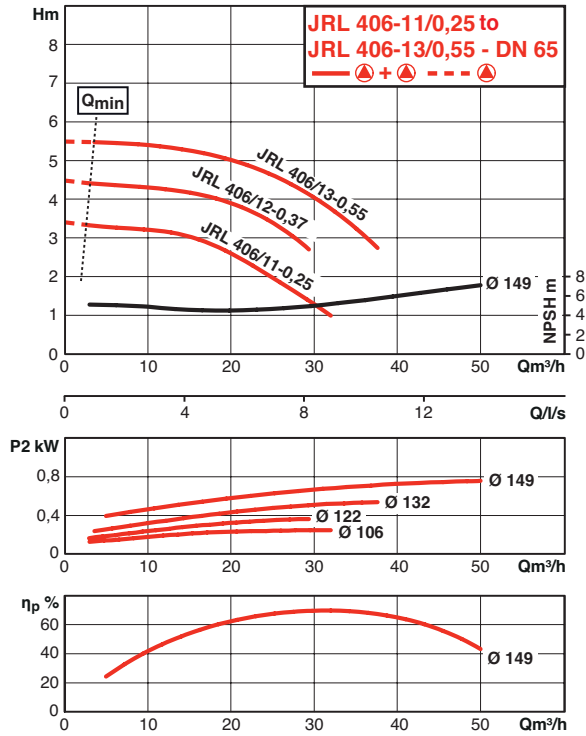

HYDRAULIC PERFORMANCE JRL 2 POLE

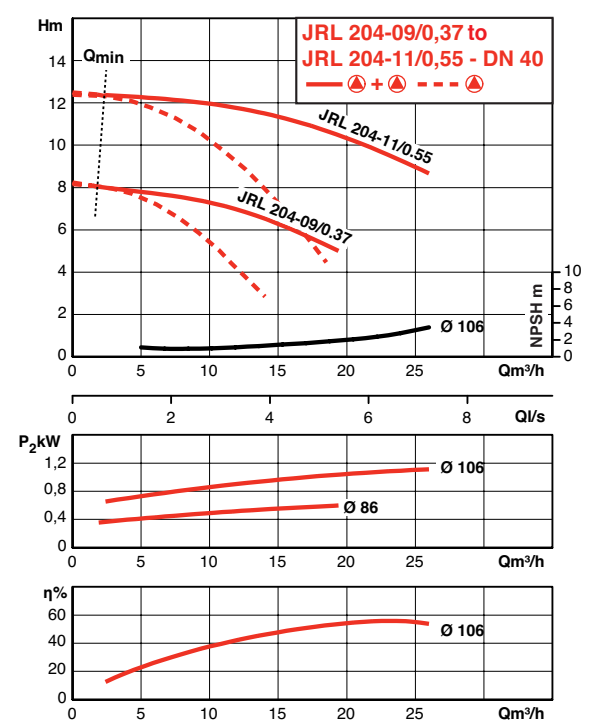
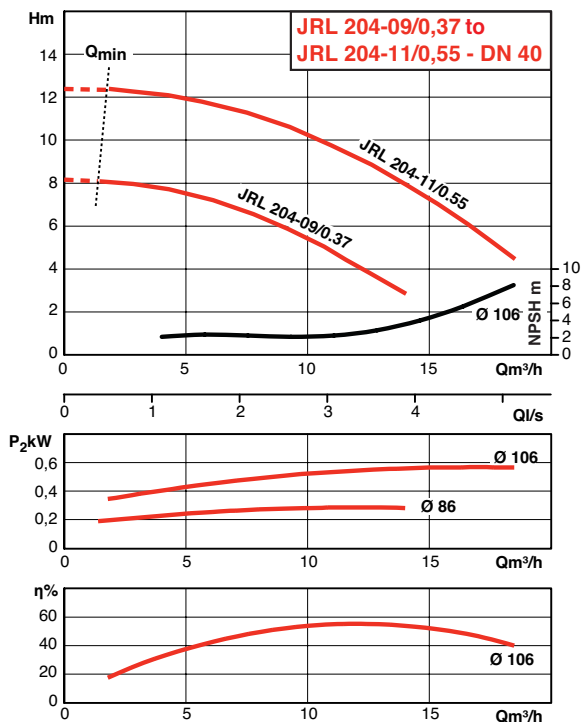
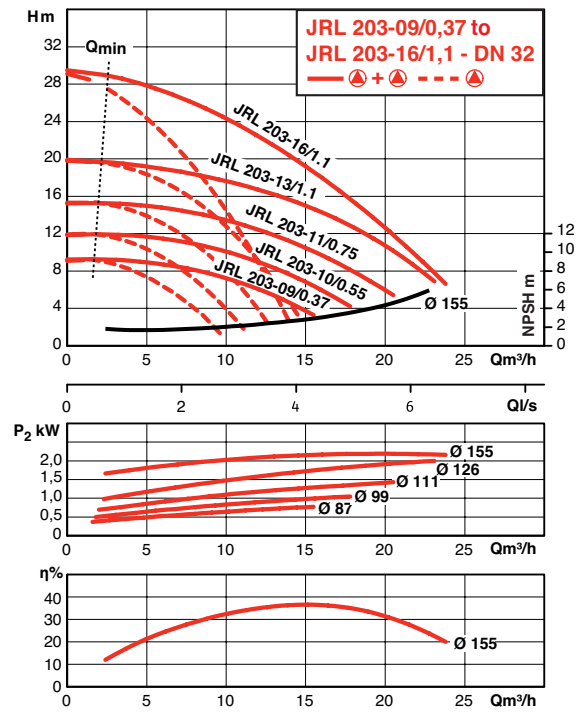
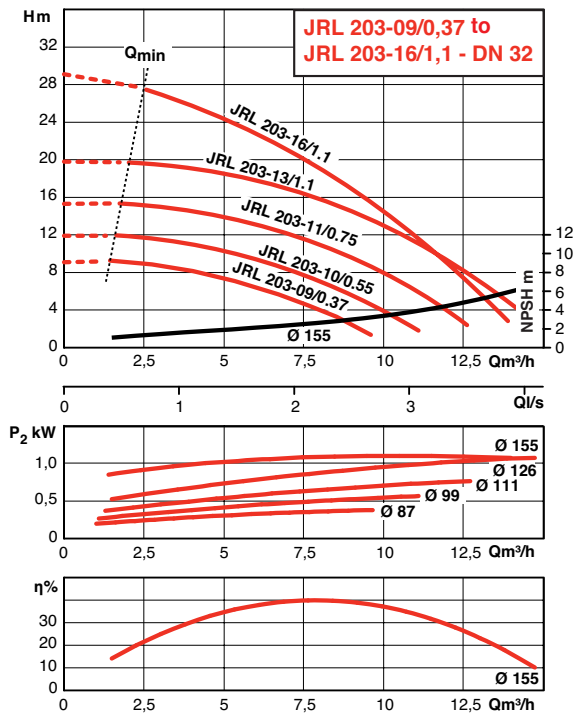

LRL - JRL

HYDRAULIC PERFORMANCE JRL 2 POLE

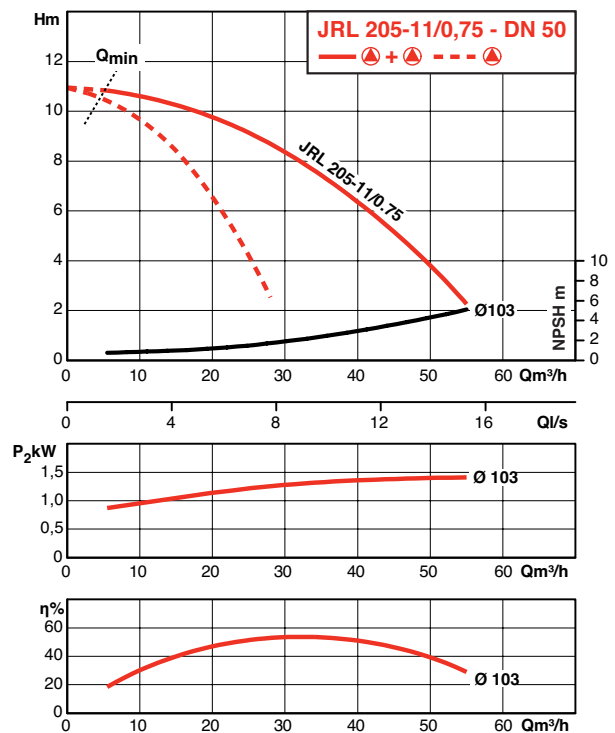
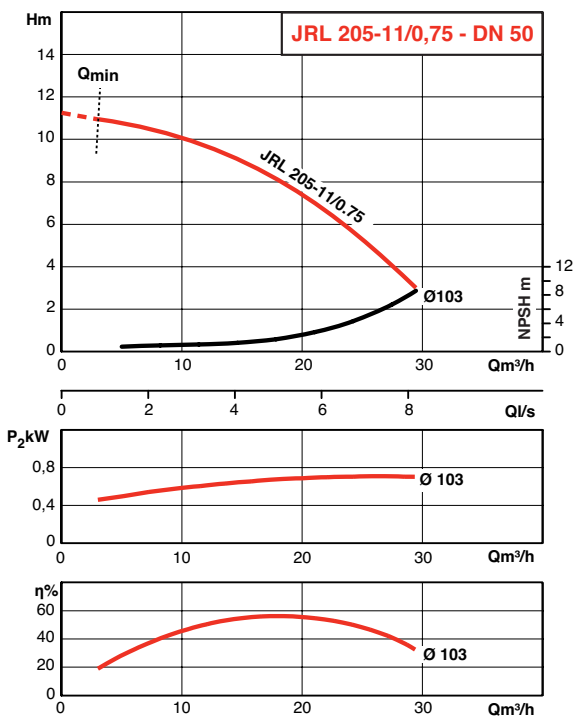
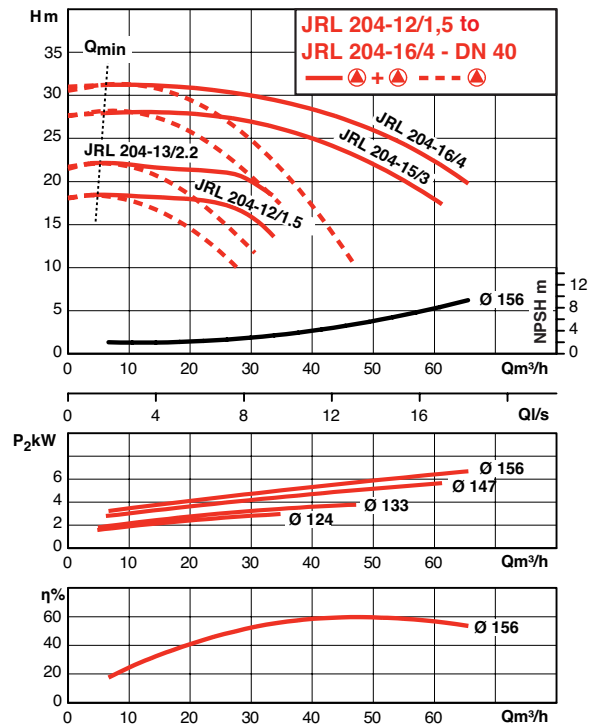
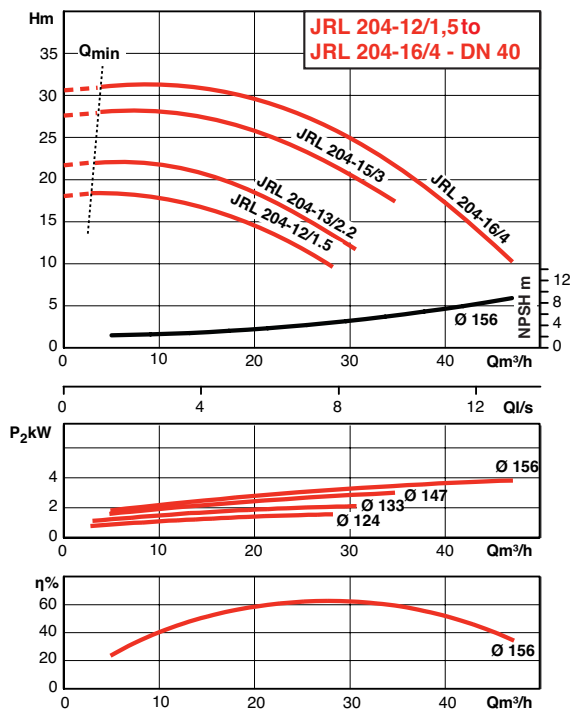

HYDRAULIC PERFORMANCE JRL 2 POLE

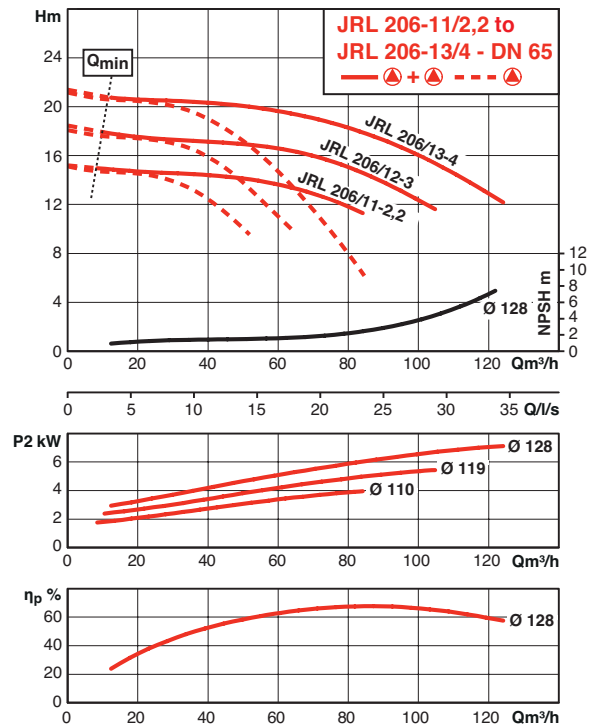
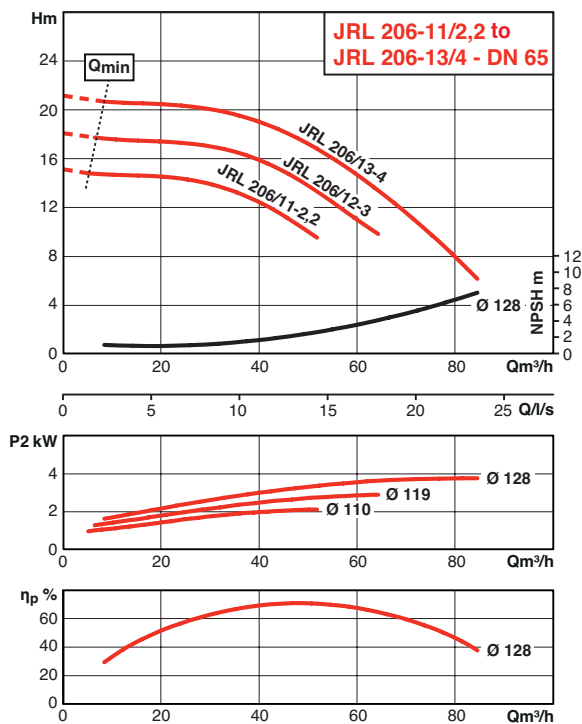
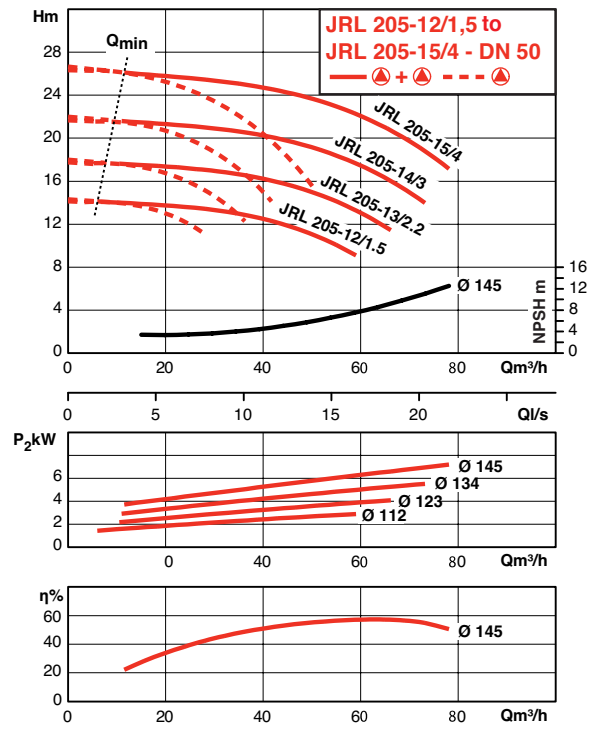
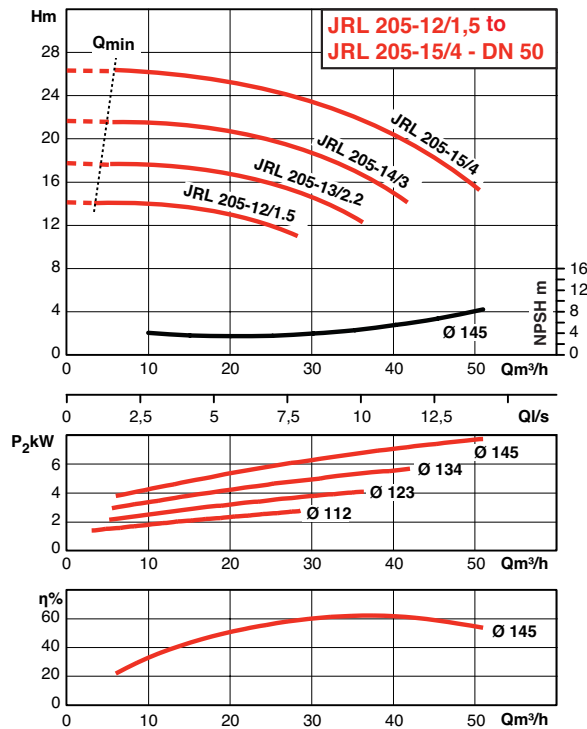

LRL - JRL

HYDRAULIC PERFORMANCE JRL 2 POLE

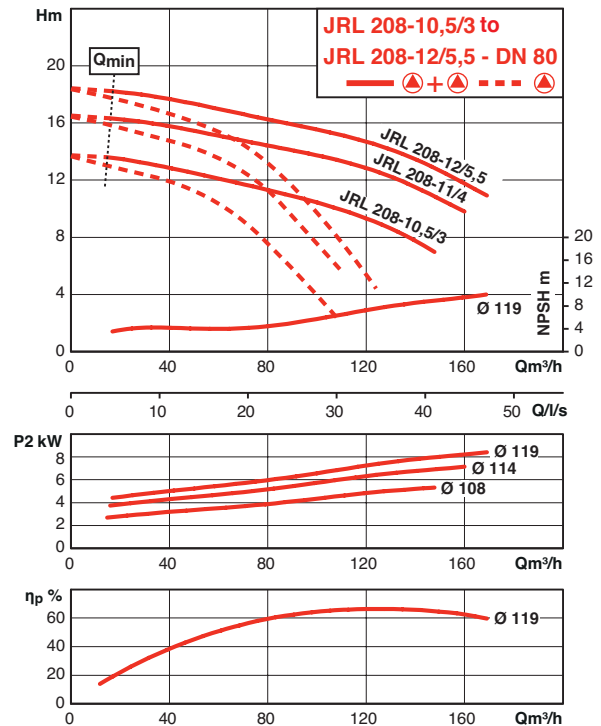
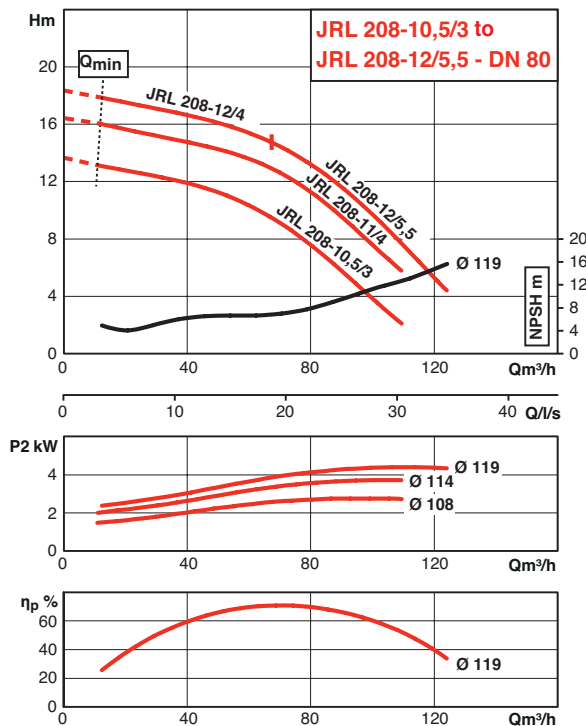
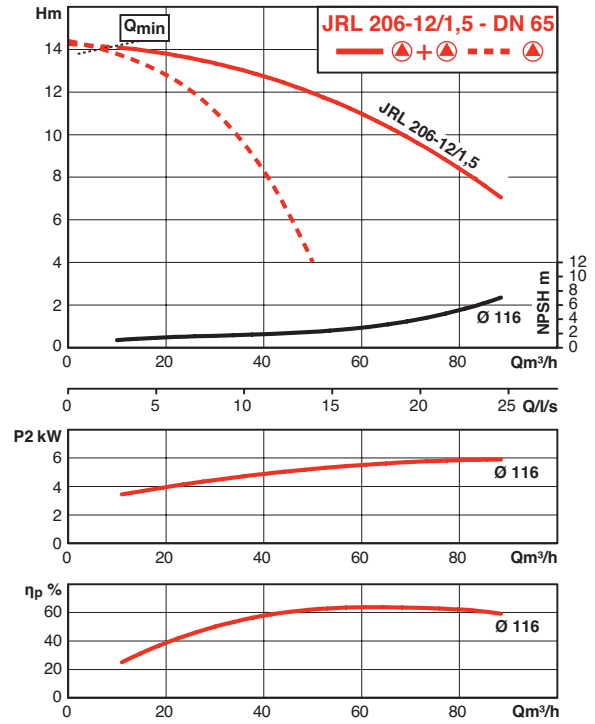
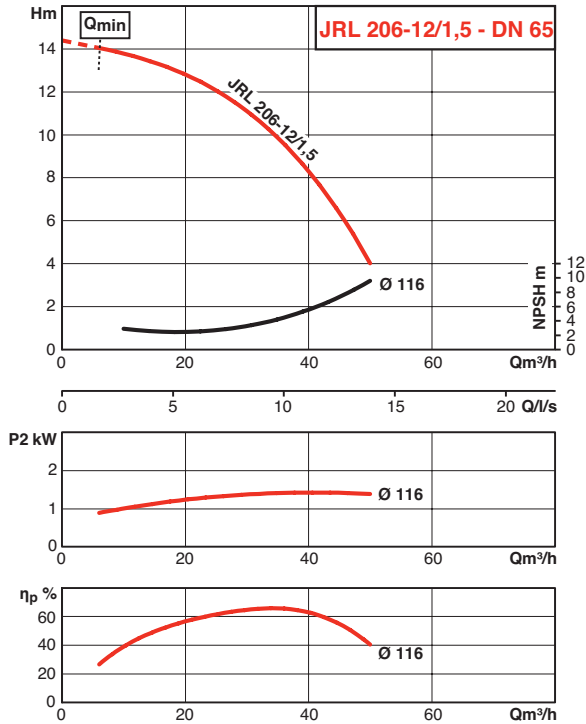

HYDRAULIC PERFORMANCE JRL 2 POLE

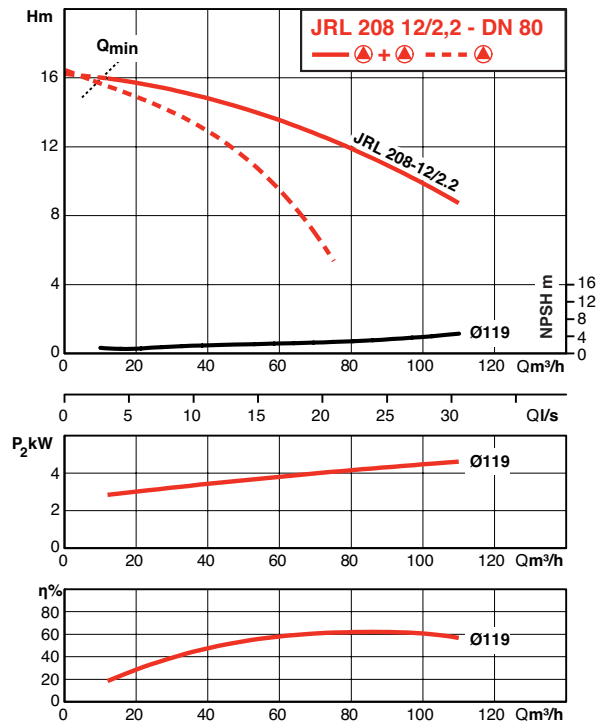
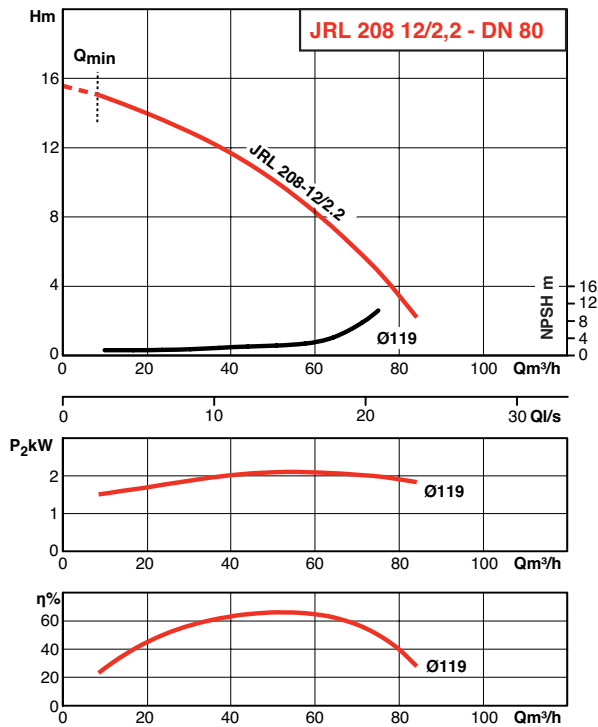

LRL - JRL

LRL-U: ELECTRICAL CHARACTERISTICS AND SIZES

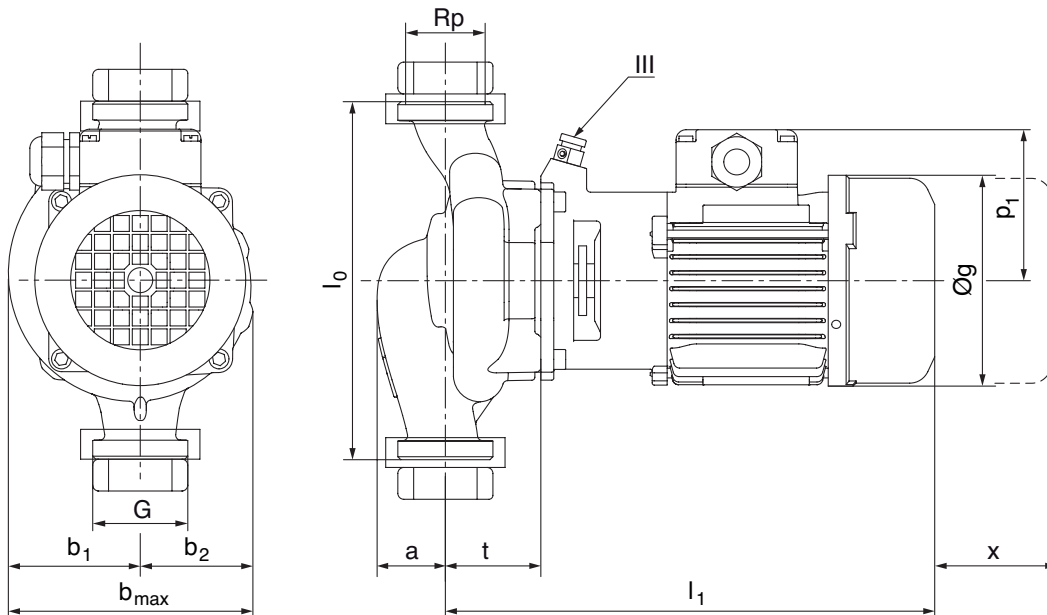

ORDER REFERENCE	MOTOR					PUMP											
	Power rating of the motor	Efficiency of motor %	Power factor	Nominal speed	Nominal current (approx.)	G	A	T	B max	B1	B2	L1	L0	P1	X	ØG	mass
	P2	η	cos φ	n	in A	mm											kg
	W																
LRL202U-07/0.12	120	64	0.75	2780	0.33	1½	34	48	123	66	57	247	180	76	100	106	6,5
LRL202U-08/0.12	120	64	0.75	2780	0.33	1½	34	48	123	66	57	247	180	76	100	106	6,5
LRL202U-08.5/0.18	180	67.4	0.72	2860	0.5	1½	52	44	137	69	68	251	180	107	100	125	8
LRL202U-09/0.25	250	69.9	0.81	2860	0.6	1½	52	44	137	69	68	251	180	107	100	125	9
LRL203U-07/0.12	120	64	0.75	2780	0.33	2	34	55	123	66	57	254	180	76	100	106	6,5
LRL203U-08.5/0.18	120	64	0.75	2780	0.33	2	34	55	123	66	57	254	180	76	100	106	6,5
LRL203U-08/0.12	180	67.4	0.72	2860	0.5	2	52	44	137	69	68	251	180	107	100	125	8
LRL203U-09/0.25	250	69.9	0.81	2860	0.6	2	52	44	137	69	68	251	180	107	100	125	8,6

LRL: ELECTRICAL CHARACTERISTICS AND SIZES

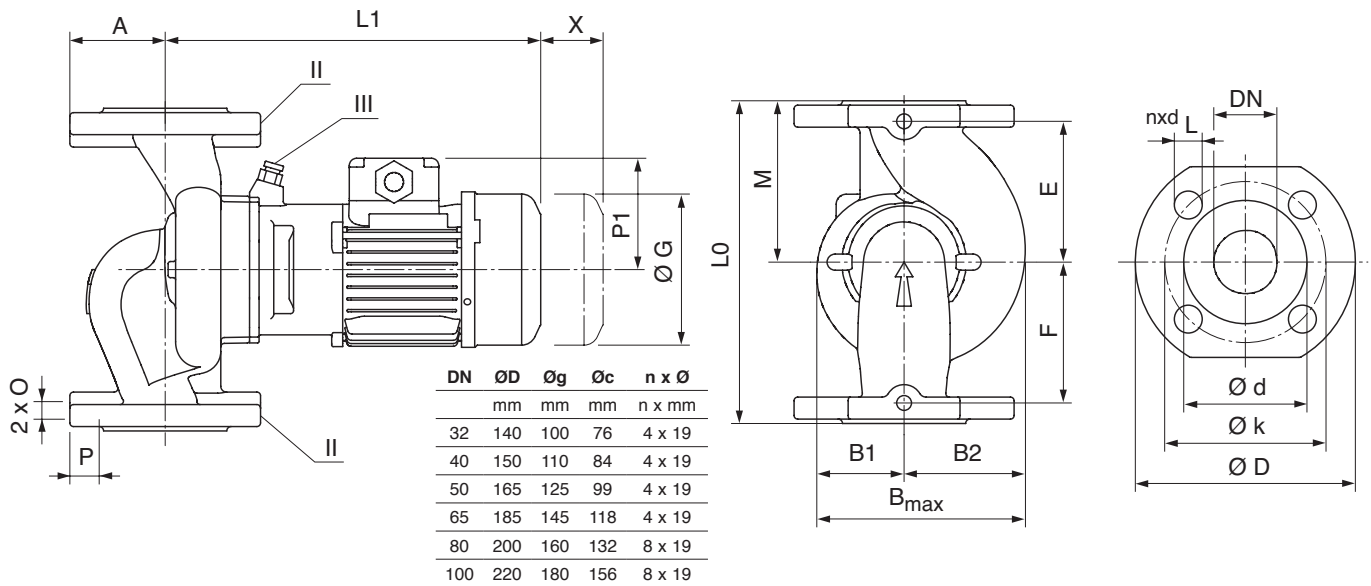

ORDER REFERENCE	MOTOR					PUMP																	mass
	P2 W	Efficiency of motor %	Power factor	Nominal speed	Nominal current (approx.)	DN	A	T	B max	B1	B2	L1	L0	P1	C	E	F	M	O	P	X	ØG	
		η	cos φ	rpm	in A	mm	mm	mm	mm	mm	mm	mm	mm	mm	mm	mm	mm	mm	mm	mm	mm	mm	
LRL203-16/1.1	370	72.8	0.78	2900	0.86	32	70	55	207	101	106	321	260	121	90	40	50	130	M10	20	150	141.2	20,7
LRL203-09/0.37	550	75.5	0.76	2900	1.33	32	70	55	207	101	106	321	260	121	90	40	50	130	M10	20	150	141.2	23
LRL203-10/0.55	750	77.4	0.81	2900	1.7	32	70	55	207	101	106	341	260	128	90	40	50	130	M10	20	150	185	25,5
LRL203-11/0.75	1100	79.6	0.83	2900	2.4	32	70	55	207	101	106	341	260	128	90	40	50	130	M10	20	150	185	26,1
LRL203-13/1.1	1100	79.6	0.83	2900	2.4	32	70	55	207	101	106	341	260	128	90	40	50	130	M10	20	150	185	26,1
LRL204-07/0.12	120	64	0.75	2780	0.33	40	65	61	159	75	84	259	220	76	-	95	95	110	M10	20	150	106	11
LRL204-09/0.37	370	72.8	0.78	2900	0.86	40	65	50	170	80	90	320	250	121	-	110	110	125	M10	20	150	141.2	19,2
LRL204-11/0.55	550	75.5	0.76	2900	1.33	40	65	50	170	80	90	320	250	121	-	110	110	125	M10	20	150	141.2	20,1
LRL204-12/1.5	1500	81.3	0.78	2900	3.3	40	75	49	234	113	121	373,5	320	149,5	90	40	50	160	M10	20	150	193	29,5
LRL204-13/2.2	2200	83.2	0.82	2900	4.52	40	75	49	234	113	121	373,5	320	149,5	90	40	50	160	M10	20	150	193	31,5
LRL204-15/3	3000	84.6	0.84	2900	6.05	40	75	49	234	113	121	408	320	169,5	90	40	50	160	M10	20	150	217	37,6
LRL204-16/4	4000	85.8	0.84	2900	7.77	40	75	49	234	113	121	439,5	320	174,5	90	40	50	160	M10	20	150	232	45,7
LRL205-11/0.75	750	77.4	0.81	2900	1.7	50	75	56	192	91	101	346	280	128	-	125	125	140	M10	20	150	146	27,2
LRL205-12/1,5	1500	81.3	0.78	2900	3.3	50	86	51	247	116	131	375,5	340	149,5	104	40	50	170	M10	20	150	193	32,5
LRL205-13/2,2	2200	83.2	0.82	2900	4.52	50	86	51	247	116	131	375,5	340	149,5	104	40	50	170	M10	20	150	193	34,5
LRL205-14/3	3000	84.6	0.84	2900	6.05	50	86	51	247	116	131	410	340	169,5	104	40	50	170	M10	20	150	217	40,6
LRL205-15/4	4000	85.8	0.84	2900	7.77	50	86	51	247	116	131	441,5	340	174,5	104	40	50	170	M10	20	150	232	48,7
LRL206-11/2,2	2200	83.2	0.82	2900	4.52	65	93	57	257	119	138	381,5	340	149,5	135	40	55	170	M10	20	150	193	37
LRL206-12/1,5	1500	81.3	0.78	2900	3.3	65	80	67	218	100	118	386,8	340	151	-	155	155	170	M10	20	150	193	34,6
LRL206-12/3	3000	84.6	0.84	2900	6.05	65	93	57	257	119	138	416	340	169,5	135	40	55	170	M10	20	150	217	43,1
LRL206-13/4	4000	85.8	0.84	2900	7.77	65	93	57	257	119	138	447,5	340	174,5	135	40	55	170	M10	20	150	232	51
LRL208-10,5/3	3000	84.6	0.84	2900	6.05	80	105	63	278	125	153	422	360	169,5	135	40	55	180	M10	20	150	217	46,9
LRL208-11/4	4000	85.8	0.84	2900	7.77	80	105	-	282	125	157	453	360	174,5	135	40	55	180	M10	20	150	232	57
LRL208-12/2,2	2200	83.2	0.82	2900	4.52	80	98	69	245	110	135	388,8	360	151	-	165	165	180	M10	20	150	193	41,5
LRL208-12/4	4000	85.8	0.84	2900	7.77	80	105	63	278	125	153	453,5	360	174,5	135	40	55	180	M10	20	150	232	55
LRL403-11/0.25	250	74	0.7	1450	0.69	32	70	55	207	101	106	297	260	120	90	40	50	130	M10	20	150	141.2	20
LRL403-16/0.25	250	74	0.7	1450	0.69	32	70	55	207	101	106	297	260	120	90	40	50	130	M10	20	150	141.2	20
LRL404-08/0.09	90	67.9	0.73	1500	0.26	40	65	65	146	68	78	272	250	107	-	110	110	125	M10	20	150	125	14,1
LRL404-11/0.12	120	69.7	0.72	1500	0.34	40	65	50	170	80	90	294	250	120	-	110	110	125	M10	20	150	141.2	18,1
LRL404-13/0.25	250	74	0.7	1450	0.69	40	75	49	234	113	121	291	320	120	90	40	50	160	M10	20	150	141.2	21
LRL404-15/0.37	370	76.1	0.71	1450	1.06	40	75	49	234	113	121	291	320	120	90	40	50	160	M10	20	150	141.2	22,2
LRL405-11/0.25	250	74	0.7	1450	0.69	50	75	56	192	91	101	298,5	280	120	-	125	125	140	M10	20	150	141.2	21,7
LRL405-12/0.25	370	76.1	0.71	1450	1.06	50	86	51	247	116	131	293	340	120	104	40	50	170	M10	20	150	141.2	24
LRL405-13/0.37	370	76.1	0.71	1450	1.06	50	86	51	247	116	131	293	340	120	104	40	50	170	M10	20	150	141.2	25,2
LRL405-15/0.55	550	78.1	0.71	1450	1.45	50	86	51	247	116	131	327	340	128	104	40	50	170	M10	20	150	185	29
LRL406-11/0.25	250	74	0.7	1450	0.69	65	93	57	257	119	138	299	340	120	135	40	55	170	M10	20	150	141.2	26,5
LRL406-12/0.37	370	76.1	0.71	1450	1.06	65	93	57	257	119	138	299	340	120	135	40	55	170	M10	20	150	141.2	27,7
LRL406-13/0.55	550	78.1	0.71	1450	1.45	65	93	57	257	119	138	333	340	128	135	40	55	170	M10	20	150	185	31,5
LRL408-12,5/0.75	750	79.6	0.72	1450	1.9	80	105	63	278	125	153	339	360	128	135	40	55	180	M10	20	150	185	36,4
LRL408-12/0.55	550	78.1	0.71	1450	1.45	80	105	-	282	125	157	338,5	360	128	135	40	55	180	M10	20	150	185	37,3
LRL408-14/1.1	1100	81.4	0.78	1450	2.5	80	105	63	278	125	153	372,5	360	146	135	40	55	180	M10	20	150	176.5	40,8

LRL - JRL

JRL: ELECTRICAL CHARACTERISTICS AND SIZES

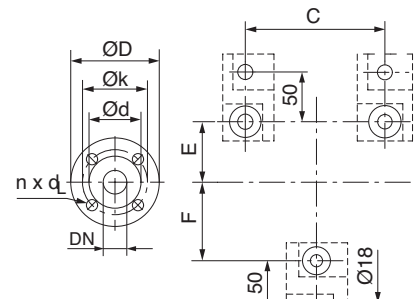
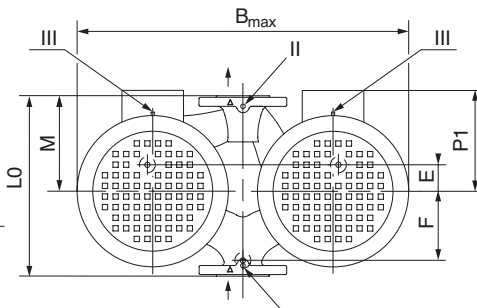
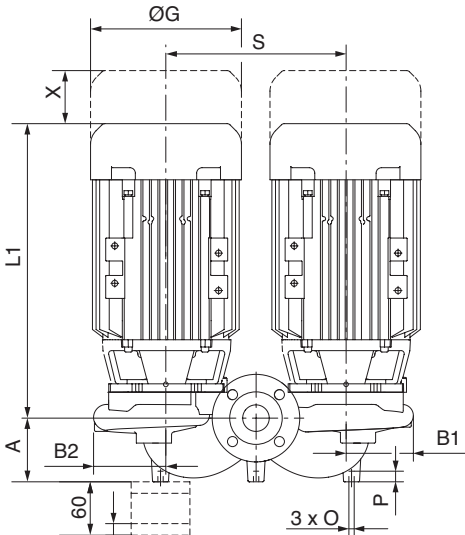

DN	ØD	Øg	Øc	n x Ø
mm	mm	mm	mm	n x mm
32	140	100	76	4 x 19
40	150	110	84	4 x 19
50	165	125	99	4 x 19
65	185	145	118	4 x 19
80	200	160	132	8 x 19
100	220	180	156	8 x 19

ORDER REFERENCE	MOTOR					PUMP														mass kg			
	P2	Efficiency of motor %	Power factor	Nominal speed	Nominal current (approx.)	DN	L0	L1	A	B max	B1	B2	P1	C	E	F	M	O	P		S	X	ØG
	W	η	cos φ	rpm	in A	mm	mm	mm	mm	mm	mm	mm	mm	mm	mm	mm	mm	mm	mm		mm	mm	mm
JRL203-09/0.37	370	72.8	0.78	1450 - 2900	0.86	32	260	321	70	410	100.5	104.5	121	225	56	106	136	M10	20	205	150	141.2	36.7
JRL203-10/0.55	550	75.5	0.76	1450 - 2900	1.33	32	260	321	70	410	100.5	104.5	121	225	56	106	136	M10	20	205	150	141.2	41.3
JRL203-11/0.75	750	77.4	0.81	1450 - 2900	1.7	32	260	341	70	410	100.5	104.5	128	225	56	106	136	M10	20	205	150	185	46.3
JRL203-13/1.1	1100	79.6	0.83	1450 - 2900	2.4	32	260	341	70	410	100.5	104.5	128	225	56	106	136	M10	20	205	150	185	47.5
JRL203-16/1.1	1100	79.6	0.83	1450 - 2900	2.4	32	260	341	70	410	100.5	104.5	128	225	56	106	136	M10	20	205	150	185	43.3
JRL204-09/0.37	370	72.8	0.78	1450 - 2900	0.86	40	250	320	75	349.5	85	91	121	225	35	97	135	M10	20	174	150	141.2	39.2
JRL204-11/0.55	550	75.5	0.76	1450 - 2900	1.33	40	250	320	75	349.5	85	91	121	225	35	97	135	M10	20	174	150	141.2	41
JRL204-12/1.5	1500	81.3	0.78	1450 - 2900	3.3	40	320	373,5	75	456	113	119	149.5	240	45	135	167	M10	20	224	150	193	58.5
JRL204-13/2.2	2200	83.2	0.82	1450 - 2900	4.52	40	320	373,5	75	456	113	119	149.5	240	45	135	167	M10	20	224	150	193	62.5
JRL204-15/3	3000	84.6	0.84	1450 - 2900	6.05	40	320	386	75	456	113	119	169.5	240	45	135	167	M10	20	224	150	217	74.7
JRL204-16/4	4000	85.8	0.84	1450 - 2900	7.77	40	320	419,5	75	456	113	119	174.5	240	45	135	167	M10	20	224	150	232	90.9
JRL205-11/0.75	750	77.4	0.81	1450 - 2900	1.7	50	280	346	83	390	95	101	128	228	50	107	155	M10	20	194	150	146	50.1
JRL205-12/1,5	1500	81.3	0.78	1450 - 2900	3.3	50	340	375,5	86	500	120	130	149.5	240	48	132	190	M10	20	250	150	193	60.3
JRL205-13/2,2	2200	83.2	0.82	1450 - 2900	4.52	50	340	375,5	86	500	120	130	149.5	240	48	132	190	M10	20	250	150	193	64.3
JRL205-14/3	3000	84.6	0.84	1450 - 2900	6.05	50	340	388	86	500	120	130	169.5	240	48	132	190	M10	20	250	150	217	84.3
JRL205-15/4	4000	85.8	0.84	1450 - 2900	7.77	50	340	421,5	86	500	120	130	174.5	240	48	132	190	M10	20	250	150	232	92.7
JRL206-11/2.2	2200	83.2	0.82	1450 - 2900	4.52	65	340	381,5	93	550	125	135	149.5	240	43	137	185	M10	20	290	150	193	71.8
JRL206-12/1.5	1500	81.3	0.78	1450 - 2900	3.3	65	340	386,8	93	431.5	103	116.5	151	225	25	137	185	M10	20	212	150	193	66
JRL206-12/3	3000	84.6	0.84	1450 - 2900	6.05	65	340	416	93	550	125	135	169.5	240	43	137	185	M10	20	290	150	217	84
JRL206-13/4	4000	85.8	0.84	1450 - 2900	7.77	65	340	447,5	93	550	125	135	174.5	240	43	137	185	M10	20	290	150	232	100.2
JRL208-10.5/3	3000	84.6	0.84	1450 - 2900	6.05	80	360	422	103	601	134	147	169.5	240	30	150	192	M10	20	320	150	217	87.2
JRL208-11/4	4000	85.8	0.84	1450 - 2900	7.77	80	360	454	103	601	134	147	174.5	240	30	150	192	M10	20	320	150	232	103
JRL208-12/2.2	2200	83.2	0.82	1450 - 2900	4.52	80	360	388,8	100	479.5	113	131.5	151	240	43	137	205	M10	20	235	150	193	76.2
JRL208-12/4	4000	85.8	0.84	1450 - 2900	7.77	80	360	454	103	601	134	147	174.5	240	30	150	192	M10	20	320	150	232	103.4
JRL208-12/5,5	5500		0.85	1450 - 2900	10.7	80	360	433,5	103	601	134	147	168	240	30	150	192	M10	20	320	150	232	105
JRL403-11/0.25	250	74	0.7	1450 - 2900	0.69	32	260	297	70	410	100.5	104.5	120	225	56	106	136	M10	20	205	150	141.2	35.3
JRL403-16/0.25	250	74	0.7	1450 - 2900	0.69	32	260	297	70	410	100.5	104.5	120	225	56	106	136	M10	20	205	150	141.2	34.3

JRL: ELECTRICAL CHARACTERISTICS AND SIZES

ORDER REFERENCE	MOTOR					PUMP																	mass kg
	P2 W	Efficiency of motor η %	Power factor cos φ	Nominal speed rpm	Nominal current (approx.) in A	DN	L0	L1	A	B max	B1	B2	P1	C	E	F	M	O	P	S	X	ØG	
						mm	mm	mm	mm	mm	mm	mm	mm	mm	mm	mm	mm	mm	mm	mm	mm	mm	
JRL404-13/0.25	250	74	0.7	1450 - 2900	0.69	40	320	291	75	456	113	119	120	240	45	135	167	M10	20	224	150	141.2	41.5
JRL404-15/0.37	370	76.1	0.71	1450 - 2900	1.06	40	320	291	75	456	113	119	120	240	45	135	167	M10	20	224	150	141.2	43.9
JRL405-11/0.25	250	74	0.7	1450 - 2900	0.69	50	280	298,5	83	390	95	101	120	228	50	107	155	M10	20	194	150	141.2	39.1
JRL405-13/0.37	370	76.1	0.71	1450 - 2900	1.06	50	340	293	86	500	120	130	120	240	48	132	190	M10	20	250	150	141.2	45.7
JRL405-15/0.55	550	78.1	0.71	1450 - 2900	1.45	50	340	327	86	500	120	130	128	240	48	132	190	M10	20	250	150	185	53.3
JRL406-11/0.25	250	74	0.7	1450 - 2900	0.69	65	340	299	93	550	125	135	120	240	43	137	185	M10	20	290	150	141.2	50.8
JRL406-12/0.37	370	76.1	0.71	1450 - 2900	1.06	65	340	299	93	550	125	135	120	240	43	137	185	M10	20	290	150	141.2	53.2
JRL406-13/0.55	550	78.1	0.71	1450 - 2900	1.45	65	340	333	93	601	125	135	128	240	43	137	185	M10	20	290	150	185	60.8
JRL408-12.5/0.75	750	79.6	0.72	1450 - 2900	1.9	80	360	339	103	601	134	147	128	240	43	150	185	M10	20	320	150	185	66.2
JRL408-12/0.55	550	78.1	0.71	1450 - 2900	1.45	80	360	339	103	601	134	147	128	240	43	150	185	M10	20	320	150	185	64
JRL408-14/1.1	110	81.4	0.78	1450 - 2900	2.5	80	360	372	103	601	134	147	146	240	43	150	185	M10	20	320	150	176.5	75

LRL - JRL

OPTIONS

Support of pump*

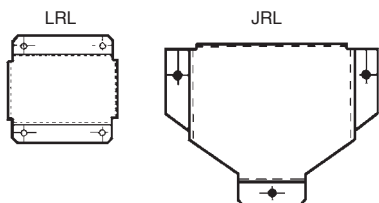

Sealing cap* for JRL

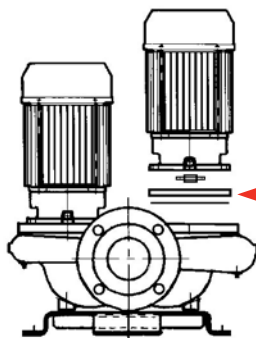

* Block the opening left by the removal of the hydraulics section and the motor. During repairs, operate on the backup pump.

cap + washer

Exchange moving parts: motor, impeller, lantern. CONTACT US

Model of pumps by family	Support of pump		Sealing cap for JRL	
	LRL	JRL	Order ref.	Item Ref.
203 - 16			COUV 160	30 908 178 F
204 - 12			COUV 120	30 925 165 P
204 - 16			COUV 160	30 908 178 F
205 - 12			COUV 120	30 925 165 P
205 - 16			COUV 160	30 908 178 F
206 - 12	30 925 701 Y	30 925 702 G	COUV 121	30 925 166 Y
206 - 16	30 925 700 P	30 925 702 G	COUV 160	30 908 178 F
208 - 12	30 925 700 P	30 925 702 G	COUV 121	30 925 166 Y
208 - 16	30 925 700 P	30 925 702 G	COUV 160	30 925 178 F
403 - 16 & 404 - 16			COUV 160	30 908 178 F
405 - 12			COUV 120	30 925 165 P
405 - 16			COUV 160	30 908 178 F
406 - 16 & 408 - 16	30 925 700 P	30 925 702 G	COUV 160	30 908 178 F

The families of pumps are indicated on the performance curves

FEATURES

a) Electrical

- THREE-PHASE 230 - 400 V - 50 Hz moteur ≤ 3 kW.
- THREE-PHASE 400 V Δ - 50 Hz moteur = 4kW.
- Motor protected by slave switch on the LRL and MGP box on the JRL.

b) Installation

- Directly onto horizontal or vertical pipework.
- Connect to the installation by round soldered backflanges nominal press. 10 (not provided).
- The system must provide protection of the pump against bad weather and frost (do not expose to direct sunlight or rain).

Option

Pump support to be fixed to concrete blockwork for nominal diameter 65 and 80 models (contact us for further details for other types).

c) Packaging

Pumps delivered with joints and bolts, without backflanges (optional extra).

d) Maintenance

Standard repair or exchange of the complete pump; see recommended spare parts (*) subject to wear.

MGP CONTROL BOX FOR JRL

- Controls motors and provides thermal protection.
- Safeguards operation by automatically starting the backup pump, if there is a fault on the pump in service.

For further information, see specific manual for MGP boxes.

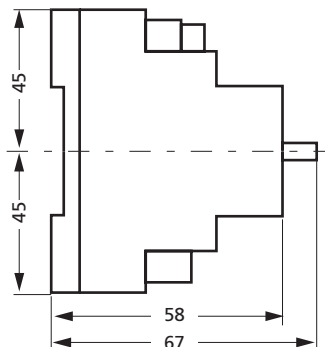
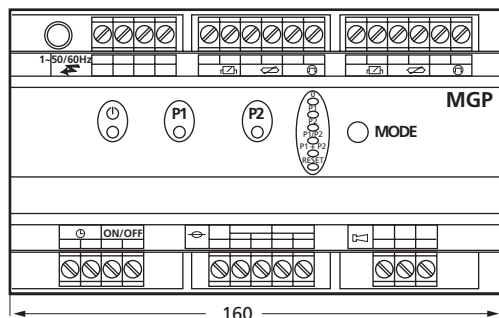
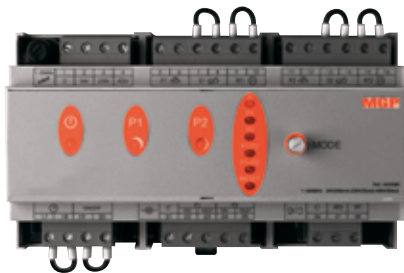

ACCESSORIES

- Slave switch of protection motor (LRL)
- Control and protection box (JRL)
- Sealing cap (JRL)
- Pressure measurement kit
- Round backflanges to solder on PN10
- Shut-off valves
- Metal rain cover (to be specified when ordering).